

Electric stair-climbing wheelchair Caterwil GTS

User
manual



- > GTS3
- > GTS3 Export
- > GTS4
- > GTS4 Lux
- > GTS5
- > GTS 4WD



CATERWIL

Contents

1. General information	4	6.1.3. Headrest height adjustment.....	25
1.1. General description	4	6.1.4. Adjusting the position of the remote control	25
1.2. Product purpose.....	4	6.1.5. Adjusting the footrest.....	27
1.3. Application area	5	7. Control.....	29
1.4. Service	5	7.1. Remote controller.....	29
2. Safety.....	6	7.1.1. Standard remote controller	29
2.1. Meaning of symbols	6	7.1.2. Remote controller with LCD display	32
2.2. General information on rules and safety.....	6	7.2. Drive range.....	37
2.3. Safety requirements for the operation of the wheelchair.....	7	7.3. Switching on and off.....	37
2.4. Safety rules for maintaining the wheelchair in working order. Maintenance and disposal.....	13	7.4. Wheelchair movement	38
2.5. Requirements for the user	14	7.5. Wheelchair movement in the pushing mode.....	39
2.6. Safety features.....	14	7.6. Batteries specifications.....	40
3. Product description	15	7.7. Charging.....	42
4. Transportation and preparation of the <i>Product</i> for use	18	7.8. Battery charger	43
4.1. Delivery set.....	18	8. Movement modes.....	44
4.2. Start of operation.....	20	8.1. Movement “On tracks”	44
5. Transport and storage	21	8.2. Movement on wheelchair GTS 4WD.....	46
5.1. Preparing for transportation	21	9. Additional options.....	47
5.2. Storage	22	10. Safety features	52
6. Service.....	23	11. Fault and troubleshooting.....	53
6.1. Adjustment options.....	23	12. Maintenance, cleaning and disinfection.....	57
6.1.1. Adjusting the wheelchair backrest	23	12.1. Drive wheel service	58
6.1.2. Armrest height adjustment	24	12.2. Steering wheel service	58
		12.3. Tensioning the tracks.....	59
		12.4. Chain lubrication	59

12.5.	Cleaning	60
13.	Legal Notice	61
13.1.	Service life.....	61
13.2.	Responsibility.....	61
13.3.	Warranty conditions.....	61
13.4.	Warranty obligations.....	62
14.	Warranty card	63

1. General information

1.1. General description

This operating instruction offers the user and attendant all the necessary information about the design, operation and maintenance of the electric stair-climbing wheelchair Caterwil GTS (*Product*) manufactured by Caterwil LLC (*Manufacturer*). The instructions contain information that must ensure the safe operation of the *Product*, as well as help identify the causes of possible malfunctions and solve them. The information provided in this instruction is necessary for understanding, since the electric wheelchair belongs to technically complex products and its incorrect operation can affect the safety of either the user, or the people around him. Particular attention should be focused on the chapter "Safety".

1.2. Product purpose

The *Product* is designed for persons with disabilities, have problems with the musculoskeletal system, central nervous system dysfunction and other diseases that limit a person's ability to move independently. The *Product* is also recommended for patients undergoing rehabilitation after surgery and various traumas. To expand the functionality of the *Product*, the *Manufacturer* provides a number of additional options, one of which allows attendant persons to drive the wheelchair. Any use of the *Product* beyond the scope of this instruction is considered as improper use. In this case, the user is responsible for injuries, physical and property damage. Before using the *Product*, the user must read the instructions for the wheelchair in detail, as well as be instructed.

1.3. Application area

The electric wheelchair can be used with partial or full loss of motor functions of the human body due to:

- paralysis;
- limbs amputations (leg(s) amputation(s));
- limbs defects or deformities;
- contracture or joint damage;
- other diseases.

The *Product* is designed primarily for patients who can move independently using wheelchair.

When assembling individually, the following features should be considered:

- height and weight;
- physical and mental condition;
- user age;
- living conditions;
- ambient conditions.

1.4. Service

INFORMATION

Only qualified personnel instructed by the *Manufacturer* carry out maintenance and repair of the *Products*. In case of problems, please contact the specialist who selected the *Product* for you.

If you have any questions or problems with the *Product* beyond the scope of this operating instruction, please contact the *Manufacturer's* service center (see the address on the last page of the instructions)

The *Manufacturer* makes effort to provide any assistance to its clients so that they remain satisfied with this *Product* for a long time.

2. Safety

2.1. Meaning of symbols

WARNING

Warnings about possible risk of accident or serious injury.

ATTENTION

Warnings about possible risk of accident or injury.

NOTIFICATION

Warnings about possible technical damage.

INFORMATION

Instructions for servicing the *Product*. Instructions for service personnel.

2.2. General information on rules and safety

ATTENTION

Risk of accident or injury due to non-observance of the safety instructions. All safety items as described in the manual must be performed. The operating instructions must always be available to the user.

ATTENTION

Risk of accident or injury due to improper use of the *Product*. The *Product* should only be used for its intended purpose. The *Product* can be operated only after instruction.

ATTENTION

Risk of burns when handling fire. Although the seat and back cushions of the *Products* are made of fire-resistant material, they may catch fire. Take extra care when handling fire. Do not smoke or light cigarettes near the *Product*.

INFORMATION

The *Product* can be equipped with additional options offered by the *Manufacturer* only. The additional options can be installed either independently, if allowed by the instructions, or at the *Manufacturer*, if the installation requires the replacement of standard units with modernized ones.

2.3. Safety requirements for the operation of the wheelchair

WARNING

Risk of accident or injury due to defective safety devices. Before each use, the user has to check operative condition of the *Product*, especially the safety device.

Operation of the *Product* is only possible if all safety devices, such as an automatic brake, are functional. Defective brakes can cause serious injuries with fatal outcome.

ATTENTION

Risk of accidents due to operating the wheelchair without experience.

Movement in the wheelchair without sufficient experience can lead to falls and other dangerous situations. Before using the *Product*, it is necessary to practice on a flat and spacious ground.

ATTENTION

Risk of accidents due to uncontrolled movement of the *Product*.

Faults arising during the operation of the *Product* can cause uncontrolled movements. In this case, you should immediately contact the *Manufacturer*. If you find faults and problems with the product, it is necessary to stop using it, as this can be dangerous both for the user and for the people around.

WARNING

Risk of overturning *Products* using lifting platforms. Turn off the *Product* when using lifting platforms or lifts and when traveling on buses or trains.

ATTENTION

Risk of accident or injury due to improper sit in the chair or leave it.

Turn off the *Product* when sit in the chair or leave it. The footrests can only be used to support the legs. Do not stand on the footrests!

NOTIFICATION

Overload damage. The maximum passenger weight is limited to the values given in the technical specifications of the *Product* (see 3, table. 1).

NOTIFICATION

Tire damage. High air pressure in tires can damage them. Do not exceed the recommended tire pressure (see 12).

INFORMATION

The system will generate an error of the speed sensor if you start to move in idle mode of geared motors (see 7.5).

NOTIFICATION

Damage caused by overheating of the wheelchair or exposure to low temperatures. The *Product* functions normally only in a temperature range of -15 °C to +40 °C. Do not use the wheelchair outside this temperature range.

INFORMATION

After each emergency stop, turn off and turn on the *Product* control device. In case of errors, the system informs with a light code (see 11, table 6) or shows a fault message on the display, stopping the execution of uncontrolled functions. If, after restarting the control system, the *Product* displays an error again, the user can unlock the electromagnetic brakes of the wheelchair to transfer it in pushing mode (by attendant person). If it is not possible to ensure the movement of the wheelchair by muscular strength, or to ask for help from others, the *Product* can be controlled in "manual mode" (the control system must not be de-energized). Driving in "manual mode" ignores the sensor values and allows you to reach your destination, despite the blocking of the motors. However, certain faults may damage the *Product*. Evaluate the risks and use this mode only in situations where no alternative solutions to problems. After the appearance of such faults, contact the *Manufacturer* for specialist consultation.

⚠ WARNING

Risk of accident or injury due to incorrect lifting of the wheelchair.

Attendant persons should only lift the wheelchair using special handles (fig. 2.1) or the front frame beam. Do not lift the wheelchair by the footrest or armrest!



Fig. 2.1. Handles for transport

 **WARNING**

Risk of injury if the wheelchair overturning while driving.

The *Product* can overcome slopes with an angle less than 15° (24 %) in the "On wheels" mode (see fig. 2.5). Moving at angle of more than 15° (24 %) is not allowed!

The *Product* is equipped with a track platform for climbing stairs with angle of up to 35°, maximum step height — 180 mm. The *Product* is not intended for use on spiral stairs.

 **WARNING**

Risk of accidents due to the *Product* overturning while in movement.

When the *Product* moves slope, the speed should be reduced (for example, put into 1st gear). On descent and climbs, it is forbidden to overcome obstacles, leave and sit in a chair. Overcoming obstacles, descents and climbs is allowed only with the vertical position of the backrest.

Overcoming obstacles such as steps and curbs is possible only on tracks. In this case, the obstacle should be perpendicular to the direction of movement.

 **ATTENTION**

The movement on the stairs can be performed only by orienting the *Product* in front of the descent (fig. 2.6). Descending the stairs only forward. Climb stairs only backwards. In "on tracks" mode, the system will automatically maintain the horizontal position of the chair by tilting it back.

 **ATTENTION**

Driving on ramps on wheels is possible only at an inclination angle of no more than 15 degrees. If this angle is exceeded, the wheelchair should be moved on the tracks with its back to the incline. For stability when lifting, you can tilt the chair position within 14 degrees.

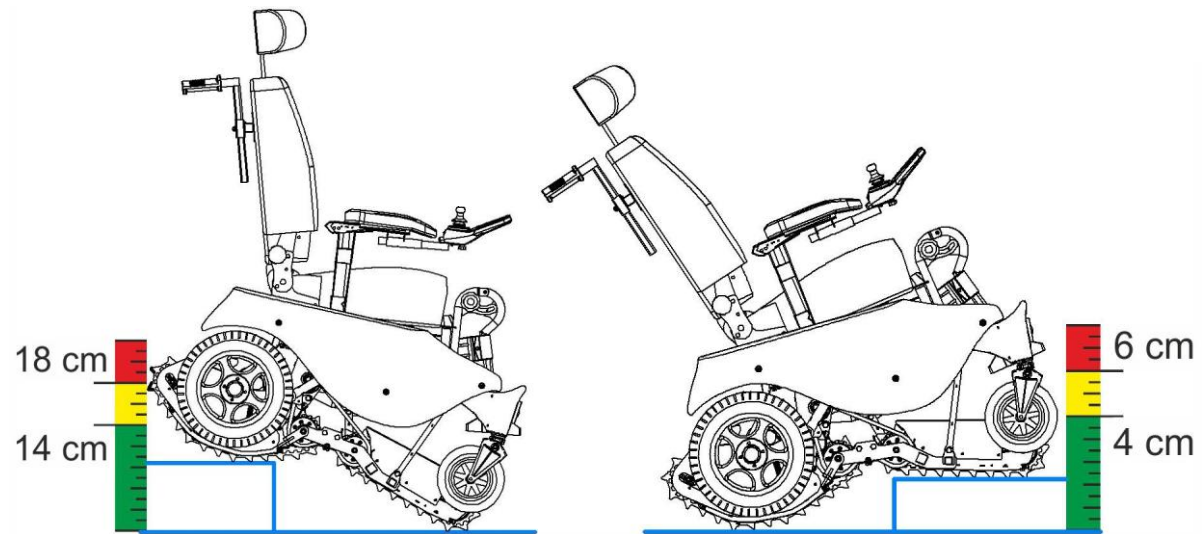

Fig. 2.2. Schematic image of wheelchair overcoming obstacle of the «step» type on the tracks

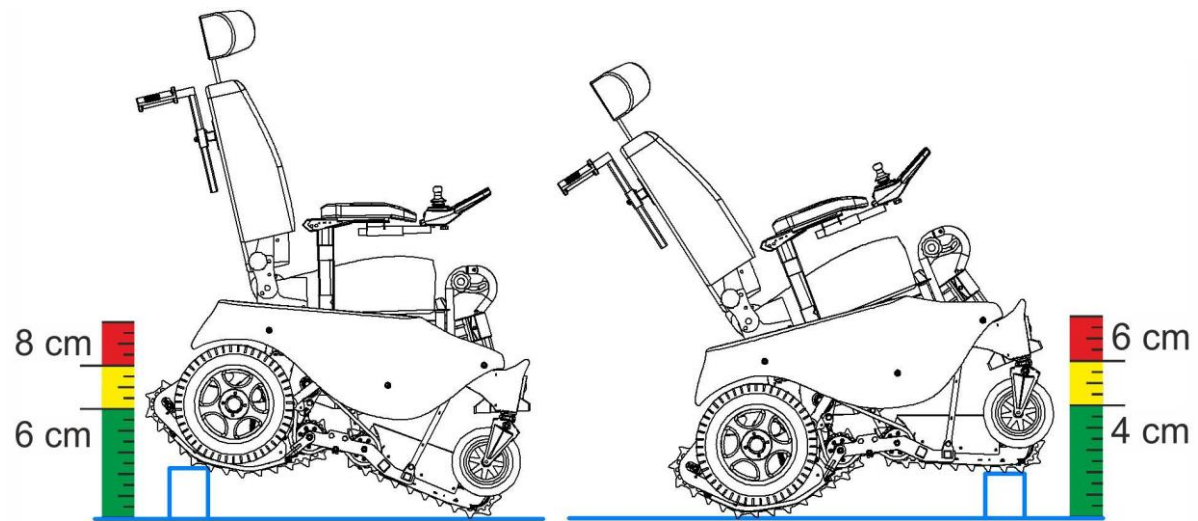

Fig. 2.3. Schematic image of wheelchair overcoming single obstacle on the tracks

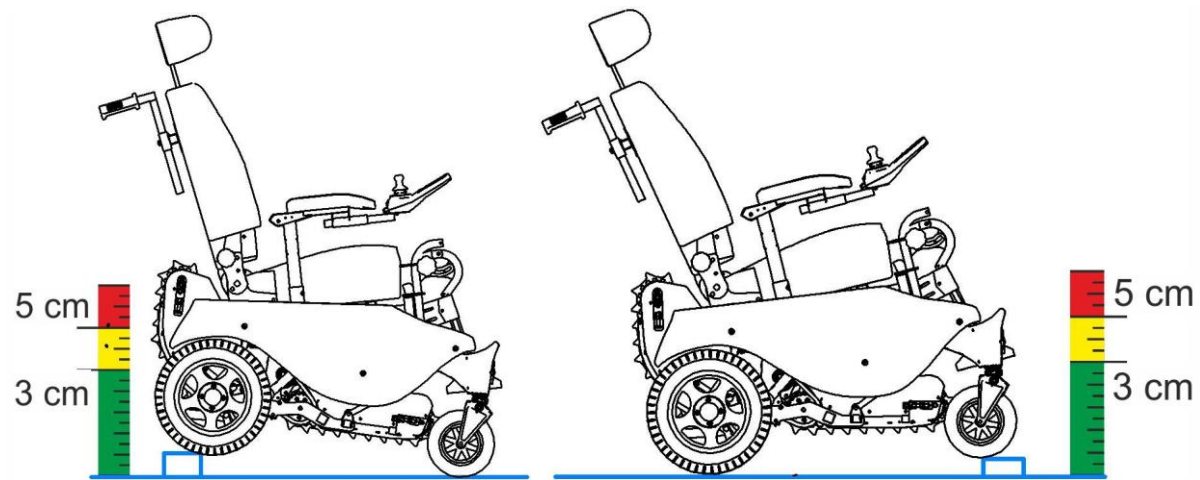

Fig. 2.4. Schematic image of wheelchair overcoming single obstacle on the wheels

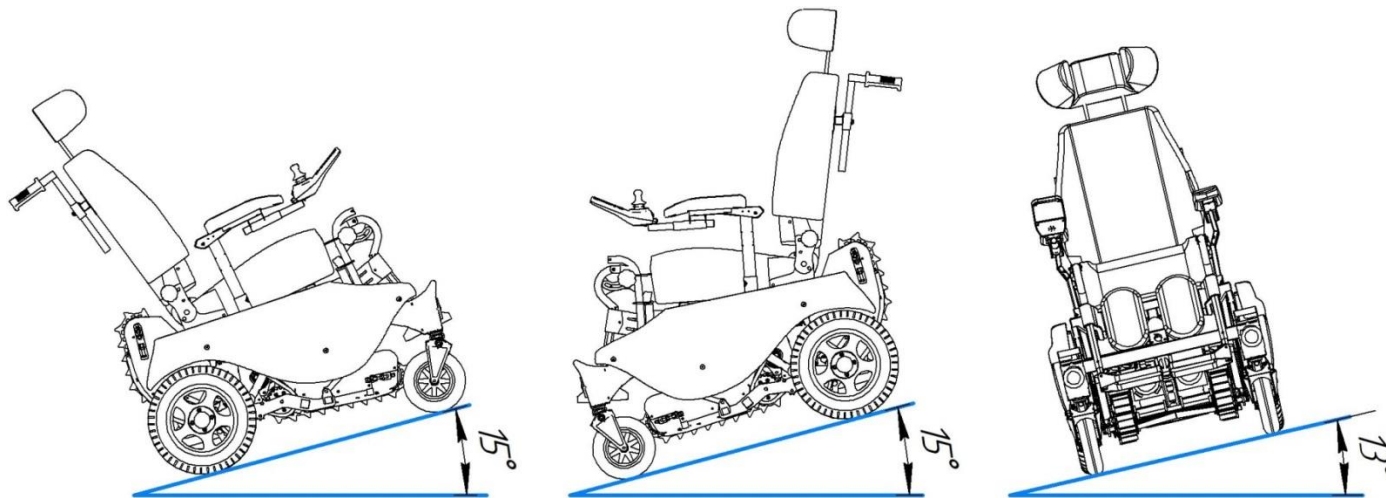

Fig. 2.5. Maximum angles of climb and descent of *Products* at movement on wheels

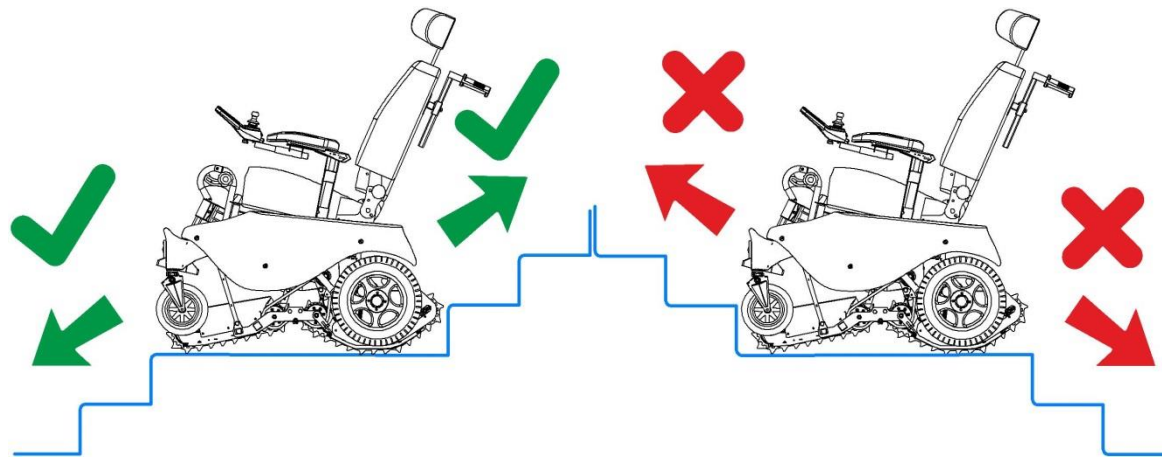

Fig. 2.6. Schematic image of the direction of movement of the wheelchair on the stairs

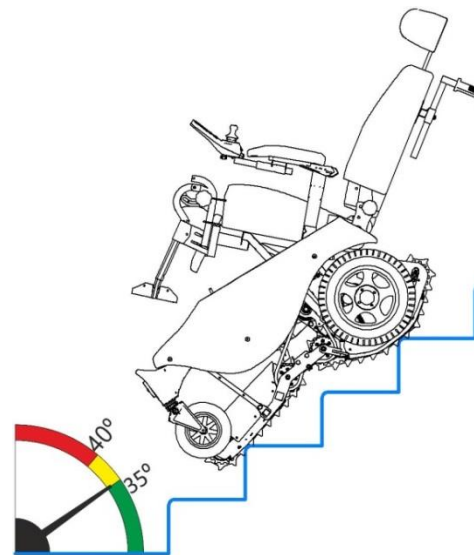

Fig. 2.7. Visual demonstration of the safety angle of stair slope

2.4. Safety rules for maintaining the wheelchair in working order. Maintenance and disposal

ATTENTION

Risk of accident or injury due to improper maintenance, repair or adjustment of the *Product*. Maintenance of the *Product* maintenance must be performed by qualified personnel instructed by the manufacturer.

NOTIFICATION

Battery replacement and charger. The battery should only be replaced by a qualified specialist. The battery must be charged exclusively with the battery charger included in the kit with the *Product*.

NOTIFICATION

Damage to electronic equipment due to water penetration. Never use a water jet or high-pressure cleaning apparatus for cleaning the wheelchair! Do not allow water to enter electronic equipment, motors and batteries.

INFORMATION

The operability of all systems of the product systems must be checked once a year by a technician.

INFORMATION

Defective batteries are disposed of in accordance with local environmental regulations

2.5. Requirements for the user

ATTENTION

Risk of accident or injury due to unprofessional use of the *Product*.

Products operation should only trust a competent user. Therefore, the user, and if necessary attendant persons, must be instructed either by the *Manufacturer* or by persons authorized by the *Manufacturer*.

The user must read the operating instruction of the product and understand the information contained therein.

Operation of the *Product* under excessive fatigue, under the influence of alcohol or medications is not allowed!

The user should not suffer from mental disorders influencing the ability to navigate in space when operating *Product*.

2.6. Safety features

INFORMATION

In case of danger, the *Product* can be turned off at any time using the "on / off" button.

When the button is pressed, the *Product* is immediately decelerated and all electrical functions are disabled.

In case of faults (e.g., there is not power supply to the brake), they are immediately identified by the software, then an emergency braking of the *Product* occurs or the speed decreases. At the same time, a warning beep sounds and the error message is displayed.

3. Product description

The *Product* is designed for use in everyday life and empowering people who have partially or completely lost the function of the musculoskeletal system. The presence of the track platform and an automatic seat deflection system allows the user to independently overcoming stairs and curbs.

The *Product* is wheelchair based on two combined platforms - wheeled and tracked. Wheels are used to move on flat ground, and track platform is needed to climb stairs, curbs and other obstacles. The track platform is activated using the control panel.

To control the *Product*, the *Manufacturer* has developed its own control system. Depending on the model and individual wishes of the user, the *Product* can be completed with a conventional remote controller, as well as a remote controller with LCD display. The difference between the remote controllers is the amount of information available to the user. Any control panel displays information about the actual status of the wheelchair: the selected mode, the selected maximum speed and battery charge. In case of error, the control panel displays it with a code light signal or message on the LCD display.

The control system allows you to customize the control system according to the user's needs. The list of settings includes: setting the sensitivity of the joystick, maximum speed, seat tilt in a limited range ("on wheels" mode), as well as turning on and off the headlights.

Table 1. Specifications of GTS Series *Products*

Characteristic	GTS3	GTS3 Export	GTS4 Lux	GTS5	GTS 4WD	Notes
Dimensions in working state, mm (LxWxH)	(1020-1400)x650x1230		(1020-1400)x650x1400	(1020-1400)x650x1230		Length depends on legrest position
Dimensions in folded state, mm (LxWxH)	1020x650x780		1020x650x1400	1020x650x780	920x650x750	The GTS4 Lux cannot be folded down for transport
Seat height, mm	560					
Seat width, mm	450		520	450		
Seat depth, mm	450		500	450		
Seat back height, mm	530		650	530		
Armrest height, mm	150–300					Adjustable
Lower leg length, mm	380–540					Adjustable
Weight (with accumulator batteries), kg	115	98	114	98		
Max load capacity, kg	100	115	100	115		
Front wheel size, mm	200				100	For the GTS 4WD, the diameter of the additional wheels is specified for the rear-wheel drive mode.
Drive wheel size, mm	320				355	
Max speed on wheels, km/h	7	8			7	
Max speed on tracks, km/h	0,7	0,8				
Max mileage in mode "on wheels", km	18	25				For GTS 4WD, mileage is indicated in rear-wheel drive mode
Max mileage in mode "on tracks", steps	600	900				50 % descent/50 % climb
Max stairs angle, deg	35					At step height 150 mm, step rounding radius 10 mm
Max step height, mm	180					At stair angle 25 deg, step rounding radius 10 mm
Max step rounding radius, mm	20					At stair angle 25 deg

Characteristic	GTS3	GTS3 Export	GTS4 Lux	GTS5	GTS 4WD	Notes
Noise level, dBA	≤75					
Operating temperature, °C	-15 ... +40					
Battery capacity, A*h	33	42				
Battery type	AGM	Lithium				
Drive motors voltage, V	24					
Charger power requirements, V	220					
Nominal charging current, A	5					
Wheelchair protective system	IP54					
Lighting equipment	None	Front and rear lights				
Front wheel type	Foamed core	Pneumatic				
Rear wheel type	Foamed core	Pneumatic				
Speed sensor	—	—	Set			
Seat back angle adjustment	Mechanical		Electric	Mechanical		
Legrest angle adjustment	Mechanical		Electric	Mechanical		

4. Transportation and preparation of the *Product* for use

4.1. Delivery set

INFORMATION

All options included in delivery set depend on the model of the wheelchair.

Delivery set included:

- Electric stair-climbing wheelchair GTS series with main components
- Charger;
- Operating instructions;
- Options (see chapter 9).

The dealer delivers the *Product* in a ready-to-use condition. Individual adjustments for a particular user must be carried out independently before starting operation. The functions of individual components can be checked using the instructions given in chapter 6. Chapter 11 contains description of possible fault of the wheelchair.



Fig. 4.1. Wheelchair front view:

- 1 — headrest;
- 2 — seat;
- 3 — remote controller;
- 4 — armrest;
- 5 — legrest



Fig. 4.2. Wheelchair back view:

- 6 — assistants handle;
- 7 — pocket;
- 8 — battery module

4.2. Start of operation

Before using the Product, it is necessary to check the presence of all items included in the standard set (see fig. 4.1, 4.2), estimate their functional readiness and serviceability.

Before turning on the wheelchair, you must turn on the automatic switch (fig. 4.3). The automatic switch turns off the wheelchair in case of short circuit or overload. To turn on the wheelchair, you must turn the automatic switch to the working position.

Make sure the emergency stop button is pressed (see fig. 7.1). If the button is off, press it to activate the power of the wheelchair. Press the power button on the remote control.

The wheelchair is ready for use in one second. The wheelchair is in safe mode after starting until the drive mode is not selected ("on wheels" or "on tracks").

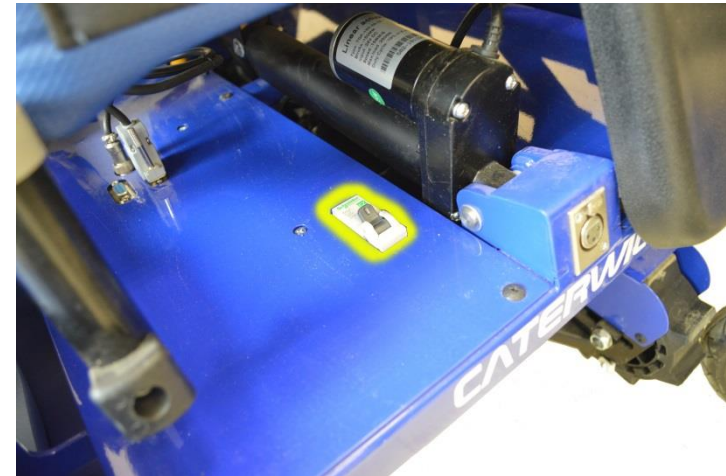

Fig. 4.3. Automatic switch

5. Transport and storage

5.1. Preparing for transportation

To transport the Product in the trunk of a vehicle or airplane, you need to prepare it for transportation.

- Remove the footrests. Press the lever at the base of the footrest to the chair frame and pull up (see fig. 6.6).
- Fold the seat into the transport position, pull the lever up, then tilt the backrest forward (see fig. 5.1).
- If the armrests are raised high, they can be lowered. To do this, unscrew the fixing bolts (see Fig. 6.2).
- If the *Product* is to be transported in the aircraft luggage space, the drive wheels should be set to idle mode (see fig. 7.13).
- If the *Product* is supposed to be transported in the luggage compartment of the aircraft, the drive wheels should be set to idle mode (Fig. 7.13). For the GTS 4WD model, you must select the rear-wheel drive mode.
- If the *Product* will be transported in the trunk of a personal car, it can be loaded into it along the ramps. Depending on the design of the ramps, the *Product* can independently enter the trunk on wheels or tracks.
- To avoid damaging the remote control, remove it from the holder and place it on the seat.
- Turn off the *Product* by turning the automatic switch to the off position (see fig. 4.3).



Fig. 5.1. Folding the backrest to the transport state

5.2. Storage

When storing the *Product*, you should follow a number of simple recommendations below. This will keep the external and technical condition of the wheelchair for a long time.

Transport and storage Products are allowed in the temperature range from -15 ° C to + 40 ° C.

Store the *Product* in a room with a relative humidity not exceeding 60%.

INFORMATION

Avoid storage in the open air and a humid environment. This can result in poor performance of electrical components, damage, or failure.

INFORMATION

Tires contain substances that can react chemically with other chemicals (eg cleaning agents, acids, etc.).

INFORMATION

If the *Product* is rarely used, is idle for a long time or is not used for several days, then it is necessary to provide the wheelchair with a supporting surface or a substrate where it can be installed. Otherwise, dark spots that are difficult to remove may appear where the tires contact with the surface.

INFORMATION

Direct sunlight/ultraviolet radiation will cause tires to age rapidly. This will lead to a decrease in the elasticity of the rubber, embrittlement of the profile surface, the appearance of a mesh of cracks and, as a result, rapid wear. Try to avoid prolonged open air parking unnecessarily.

INFORMATION

Independently of wear, operating conditions and usage, tires should be replaced every 2 years.

INFORMATION

During prolonged idle or transportation of the *Product*, it must be de-energized using automatic switch.

6. Service

6.1. Adjustment options

When developing Caterwil wheelchair, great attention is paid to the ergonomic component of the *Products*. For this reason, all electric wheelchairs have a large number of settings, allowing the user to choose the most optimal and comfortable placement in the chair.

The *Manufacturer* offers the following adjustments for the *Product*, which the user can make on his own:

- Backrest angle;
- Seat angle;
- Armrest height;
- Footrest length;
- Footrest angle;
- Headrest height.

The footrests can be removed if necessary.

6.1.1. Adjusting the wheelchair backrest

The backrest tilt mechanism has a similar design to the mechanisms that are installed on modern cars. This design allows you to adjust the backrest position in the range from 90 to 180 degrees in relation to the plane of the seat, as well as fold the chair for transportation, making it more compact. The backrest angle is adjusted using a lever at the base of the chair (see fig. 6.1). To increase the angle of inclination, you need to pull it towards yourself, press on the back, set the angle and then release the lever. If, when lifting, the back of the chair does not meet resistance, then it will take a vertical position corresponding to an angle of 90 degrees.

To move the chair to the transport position, pull the lever up, push the backrest of the back and fold.



Fig. 6.1. Backrest adjustment

6.1.2. Armrest height adjustment

The product is supplied with adjustable height armrests. To adjust, loosen the thumbscrew on the chair frame and set the armrest to the required height, then the thumbscrew back (fig. 6.2).

If it is necessary to pull out the armrest, it can be removed after loosening the thumbscrew by pulling up on the exit from the rail frame.



Fig. 6.2. Adjustable height armrests

6.1.3. Headrest height adjustment

Stair-climbing wheelchairs is equipped with adjustable headrests. Adjustment of the headrest in height is carried out as follows: you must simultaneously press the plastic clips of the rails (left and right), set the height, release the clips (fig.6.3). If the clips does not fit into the groove of the rail, you should make a slight adjustment to the position of the headrest (move up or down to the nearest groove to fix the position). To remove the headrest, after pressing the clips, it must be pulled up until removed.



Fig. 6.3. Headrest height adjustment

6.1.4. Adjusting the position of the remote control

NOTIFICATION

Cable damage. Improper cable routing can damage the cable. When routing, the cable should not be sagged or overstretched. Bends and clamps must also be avoided.

Removing the remote controller

You can remove the remote controller by unscrewing the thumbscrew located on the backside of the remote controller (fig.6.4 position 1)

To do this, it is necessary to make several turns of the thumbscrew until the console begins to move freely in the seat. Then apply slight pressure to the front and pull it forward. If the remote controller is not removed after that, then you should make one more turn of the thumbscrew and try again.

Another way to remove the remote controller is to completely unscrew the thumbscrew. In this case, the remote control is removed without additional manipulation. Remember that the thumbscrew will need to be screwed back in to install the remote controller back.

Before removing the remote controller, make sure that the wire is long enough for free removal and that it can move freely. Otherwise, there is a possibility of damage to the cable.

Adjusting the position of the remote controller

To adjust the position of the remote controller to the length of the arm, loosen the thumb on the underside of the armrest (see fig. 6.4 position 2). The rail with the control panel can move forward and backward, as well as rotate around its axis (fig. 6.5). After adjustment, the thumbscrew must be screwed.

Transferring the remote control

INFORMATION

Transposition of the remote controller should only be carried out by a qualified technician.

The wheelchair remote controller is set to the right side as standard. At the request of the user, the remote controller can be moved to the other side.

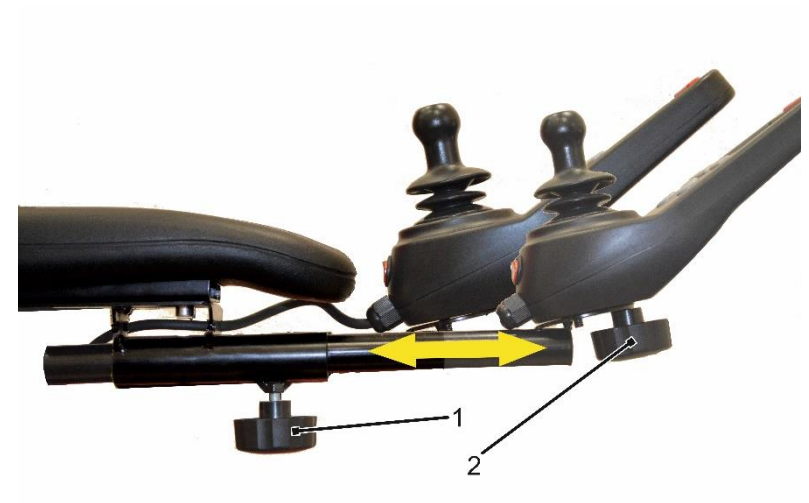

Fig. 6.4. Adjusting the length of the remote controller



Fig. 6.5. Adjusting the tilt of the remote controller

6.1.5. Adjusting the footrest

⚠ ATTENTION

Risk of injury to fingers. Care should be taken to keep your fingers away from the hazardous area when adjusting the footrests.

Removing and installing the footrest

To remove the footrest, press the lock lever, slide the footboard up and remove (fig. 6.6).

To install the footrest in place, install the tapered guide in the hole (Fig. 6.6 dotted arrow), press the lock lever and lower the footrest until it stops.

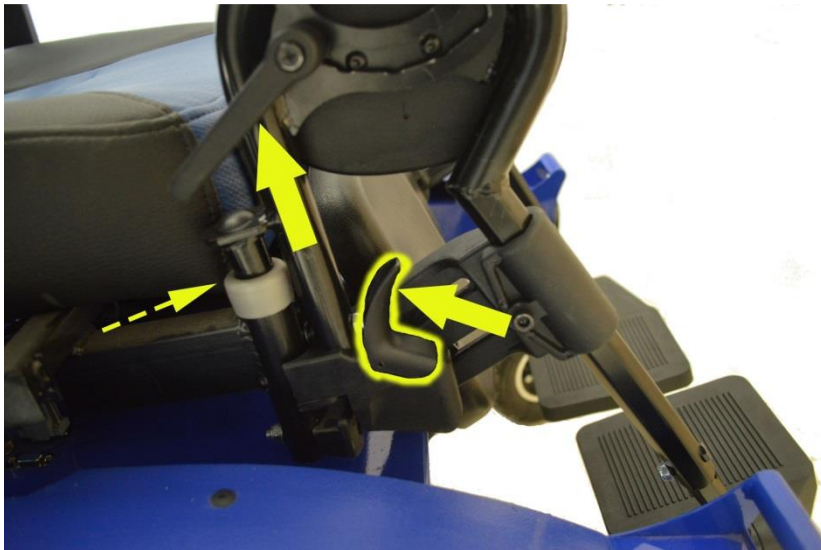

Fig. 6.6. Removing the footrest

Length adjustment of the footrest

Unscrew the bolt limitation of the footrest, set the required length, fix this position, install the bolt back and screw it (Fig. 6.7).



Fig. 6.7. Length adjustment of the footrest

INFORMATION

The length of the footrest cannot be increased by more than 160 mm.

Adjusting the angle footrest

Loosen the adjusting screw, set the footrest to the required angle, tighten the screw (Fig. 6.8).



Fig. 6.8. Adjusting the angle footrest

7. Control

7.1. Remote controller

7.1.1. Standard remote controller

The remote controller is used to control the Product (change the speed, position of the seat, switch to different driving modes), as well as to control the battery charge level. The remote controller consists of a keypad, LED display and joystick. The remote controller is used to control the power wheelchair.



Fig. 7.1. Standard remote controller:

- 1 — Chair down button;
- 2 — Chair up button;
- 3 — "On tracks" mode;
- 4 — Additional functions button Fn;
- 5 — On/Off button;
- 6 — Horn button;
- 7 — "On wheels" mode;
- 8 — Max speed down button;
- 9 — Max speed up button;
- 10 — Max speed level LED indicator;
- 11 — Battery charge LED indicator;
- 12 — Mode indicator «On Tracks»;
- 13 — Mode indicator «On Wheels»;
- 14 — Joystick;
- 15 — Emergency stop button

- **Chair up and down buttons**

Moves chair up or down in "On wheel" mode for adjusting chair angle

- **Driving mode buttons**

Switch the wheelchair to "On Tracks" or "On Wheels" mode.

- **Additional functions button Fn**

Provide additional functions in combination with other buttons.

Fn + horn button — disable / enable keypress sound.

Fn + speed up and down buttons — increases and decreases joystick sensitivity. Thus, you can choose a more relaxed style of movement of the wheelchair: with smooth turns, acceleration and smooth braking; or more dynamic: with sharp turns, acceleration and hard braking.

Fn + chair up and down buttons – switches the operating modes of the headlights (if available). Only 3 modes: no headlights, running lights and low beam.

- **On/Off button**

The on/off key is used for switching on/off the power wheelchair.

- **Horn button**

The horn will sound as long as the horn key is being pressed.

- **Speed up and down buttons**

Pressing the buttons changes the maximum speed of the wheelchair.

- **Joystick**

The joystick controls the direction and speed of travel.

- **Battery Capacity LED indicator**

The LEDs show the battery charge.

- **Speed Level LED indicator**

The LEDs show the currently selected speed level.

- **Driving Mode Indicators**

Shows the current driving mode. If this or that indicator is blinking, it means that this mode is in the process of activation.

- LED indication "Battery charge level"

INFORMATION

The power reserve given in the technical data is based on an ambient temperature of + 25 ° C. If the temperature rises or falls, the actual range will decrease.





At temperatures below 0 ° C, the battery capacity decreases significantly. As a result, the range of the electric wheelchair is reduced. Also, at low temperatures, the battery charge status displayed on the remote controller may not correspond to the actual state of charge of the battery.

The battery charge level indication is divided into 5 segments in the upper LED display field and displays the current charge level of the battery. When the battery is fully charged, all 5 LED segments light up. If the segments of the LED indication turn off one after the other, this indicates a decrease in the battery charge level (see table 2).

If only the last segment of the indicator is lit, the batteries should be charged immediately.

The battery charging process is displayed by sequential filling of all segments. The wheelchair drive function is disabled while the battery is charging.

Table 2. Battery charge indicators

Indication	Information
	The battery charged
	Charge if possible
	Low battery
	The battery is completely discharged
	The battery is charging

7.1.2 Remote controller with LCD display

Remote controller with LCD display designed to improve the usability of the Caterwil GTS wheelchair. The display shows a large amount of information and allows you to comfortably operate a large number of functions. The remote control with LCD display is analogous to the dashboard of cars.

The remote control displays information about the current speed, load on each engine, the remaining charge in percent and kilometers, wheelchair mileage, ambient temperature, atmospheric pressure, time, roll and pitch (lateral and longitudinal tilt angle) of the wheelchair and much more. The remote control has language support. From the remote control, you can adjust the sensitivity of the joystick, the mode of operation of the headlights, the tone of the signal and the time.



Fig. 7.2. Remote control with LCD display:

The select right button will perform the action indicated in the lower right corner of the display (if there is), and the select left button will respectively perform the action indicated in the lower left corner of the display.

Movement type selection menu

After turning on the wheelchair equipped with a remote control with an LCD display, it will open the "Movement type selection menu" (see fig. 7.3).

In this menu, you can select the type of travel between tracks and wheels, as well as a rear-wheel drive mode for the GTS 4WD.

The select of the mode is carried out by the buttons «Down» 4 and «Up» 5 (fig. 7.2). For GTS 4WD, you will need to confirm your selection.

If you do not select the movement type and press "next" or "back" (for the remote control from 4WD), you will go to the main screen (fig. 7.4), the wheelchair will move only in "Manual mode".

You can return to the "Movement type selection menu" by pressing the "Mode" button (Fig. 7.3).



Fig. 7.3. LCD mode selection

Main screen

The main screen (Fig. 7.4) displays: travel speed 1, mileage (total 2 and resettable 3), engine load 4, remaining battery charge 5, approximate remaining travel on this charge 6, selected travel mode 7, logotype 8, temperature 9 and headlight 10.

From this screen you can go to the mode of movement type selection "Mode" 11 and "Menu" 12.

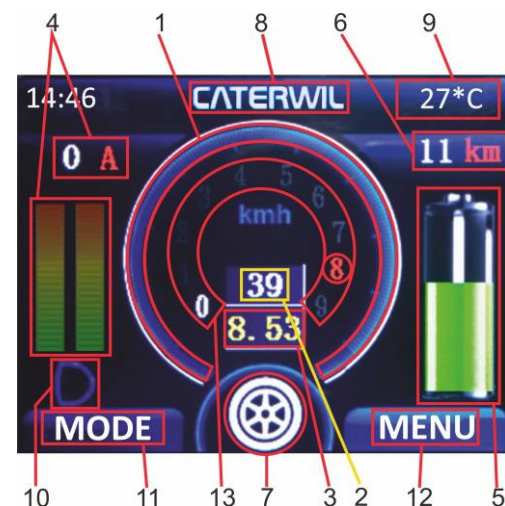

Fig. 7.4. LCD main screen

The buttons "Down" 4 and "Up" 5 (see Fig. 7.2) in this menu allow you to adjust the maximum speed of movement of the wheelchair 13 and highlight the selected maximum speed in red.

Menu

Headlight mode



Fig. 7.5. Headlight mode selection menu

On the page for selecting the operating mode of the headlights (Fig. 7.5) there are four items: "Off", "Parking lights", "Light + Parking lights", "Hazard signal". The selection is made using the "Down" and "Up" buttons. The selection of modes is repeated in a circle.

Select "Back" to exit this point.

Seat setting



Fig. 7.6. Chair angle adjustment menu

The seat setting only works when the wheelchair is in the "On wheels" or "Manual mode". In the "On wheels" mode, you can use the "Down" or "Up" buttons to change the inclination of the chair.

Select "Back" to exit the menu.

Wheelchair tilt



Fig. 7.7. Roll and Pitch Display Screen Products

In this menu, you can get data about the position of the wheelchair relative to the horizon (Fig. 7.7). This can be useful for determining the angle of the ramp the wheelchair is on.

Roll — this is tilt to the side.

Pitch — this is tilt forward and back.

Select the Back button to exit.

Display setting



Fig. 7.8. Display brightness setting menu

This menu item allows you to adjust the brightness of the display from 10 to 100% using the Down and Up buttons.

Select "Back" to exit this point.

Setting sounds



Fig. 7.9. Sound effect setting menu

This menu item allows you to adjust the sound volume, as well as turn it off.

«Manual mode»

⚠ ATTENTION

Manual mode is designed to simplify maintenance and repair of the wheelchair. When using this mode, damage to mechanisms is possible. It is forbidden to manipulate the user in the chair in this mode.

This menu item allows you to ignore errors of the protection system against incorrect operation of the wheelchair. In this menu item, you can adjust the angle of inclination of the chair, as well as switch between types of movement "on wheels" / "on tracks". Manual mode allows movement ignoring the software protection system.

Time setting



Fig. 7.10. Time setting menu

In this menu, you can adjust the time shown on the display.

It has two available windows for setting the time, corresponding to hours and minutes.

To set the time, select the required window using the "Down" or "Up" buttons and press the "Select" button, set the time, to exit the setting, press "Back".

Device Information



Рис. 7.11. Device Information Screen

In this menu item, you can view information about the wheelchair and its elements, check the software version and the year of production of the wheelchair.

To exit the menu, select "Back" or "Ok".

Joystick setting



Fig. 7.12. Joystick sensitivity setting menu

In this menu item, you can adjust the sensitivity of the joystick. To do this, use the "Down" and "Up" buttons to set the required level and press "Select".

Joystick sensitivity affects acceleration, deceleration and cornering harshness.

Select "Back" to exit the menu.

Error information

This menu item will display information about the active error. It is needed if you closed the error message without reading it.

7.2. Drive range

INFORMATION

You can find information on the range of the electric wheelchair in chapter 3 "Technical data". It should be noted that the drive range value is determined in specific conditions in accordance with GOST R ISO 7176-4. In practice, the range may be lower.

The following factors affect the range of the electric wheelchair:

- capacity and type of batteries;
- ambient temperature;
- character movement (often maneuvering and braking reduce the range);
- features of the terrain and the nature of the ground;
- user weight;
- use of electrical options.

7.3. Switching on and off

By pressing the on / off button (fig. 7.1, 5 or fig. 7.2, 1) turns on or off the wheelchair control device. If the wheelchair control device is not used for some time, the wheelchair will automatically turn off. Using the on / off button, the electric wheelchair can be turned off while in movement. In this case, an electromagnetic brake is activated on each drive, which leads to a quick stop of the *Product*.

7.4. Wheelchair movement

ATTENTION

Risk of injury from uncontrolled movement of the electric wheelchair. Switch off the wheelchair control device if it will not be used in the near future. This is to avoid random activation of the remote control.

ATTENTION

Risk of injury due to the wheelchair overturning while driving. When moving in a wheelchair, you must follow the safety rules:

- The angles of climb and descents along which the wheelchair is driven should not exceed 15 ° (24%).
- When driving on slopes, reduce the speed of the wheelchair.
- The height of obstacles to be overcome by the wheelchair should not exceed 15–50 mm, depending on the version of the *Product*.

The electric wheelchair is designed for climb and descent movement up to an angle of 15 ° (24%). Driving on climbs and descents exceeding this value is not allowed.

When driving slope, it is necessary to reduce the speed of movement of the wheelchair depending on the angle of inclination (for example, change to 1st gear).

The maximum height of obstacles that can be overcome by the *Product* on wheels is 50 mm. When overcoming steps or curbs, switch to the "On tracks" mode.

Uncontrolled movement of the wheelchair is possible on rough surfaces. Therefore, the speed of the wheelchair should always be adjusted to the terrain features.

The maximum speed with full joystick deflection depends on the gear selected.

When you release the joystick is automatically activated brake function, and the wheelchair stops. At rest, the movement of the wheelchair is blocked by an electromagnetic brake installed in the drive system.

The electric wheelchair has 5 or 7 gears depending on the type of control panel. The speed control buttons (Fig. 7.1, 8-9 or Fig. 7.2, 4-5, when the main screen is selected) is used to switch to an up or down gear. The selected gear is indicated by the "Drive mode" LED. After switching the highest / lowest gear, the pitch of the audio signal changes.

7.5. Wheelchair movement in the pushing mode

WARNING

Risk of accident or injury due to lack of braking. When the brake is released (push mode), there is no braking at all.

When the wheelchair is moving downhill, only the person attendant the user carries out the necessary braking.

NOTIFICATION

To avoid damage to the Product, it is not allowed to leave it unattended when the brake is released.

Unlocked brakes can cause the wheelchair to move uncontrollably.

If the control system fails or the battery is low, the wheelchair can be moved by pushing. To do this, the brake must be released. The brake release mechanism is located under the seat in the back of the wheelchair (Fig. 7.13) and is two yellow levers. To make it easier to turn the levers, turn the corresponding wheel forward or backward.

If you try to continue the movement by the drive, with the brake unlocked, the self-diagnosis system will generate a speed sensor error (see Ch. 11, Table 6).



Fig. 7.13. Levers for transferring the wheelchair to idle mode

7.6. Batteries specifications

INFORMATION

Regular battery checks and timely charging are essential for the operational reliability of the electric wheelchair.

GTS *products* can be equipped with several types of batteries.

The GTS3 has two sealed AGM batteries that are maintenance free.

Table 3. Battery specifications Delta HRL 12-33

Nominal voltage	12 V
Rated capacity	33 A*h
Number of cell	6
Weight	11,5 kg
Dimensions (height x length x width)	195x130x168 mm
Working temperature	-20 ... 60 °C
Charge temperature	-10 ... 60 °C
Storage temperature	-20 ... 60 °C
Self discharge per month	3 % of capacity at 20 °C
Number of cycles at 40% capacity loss	300 cycles of full charge/discharge

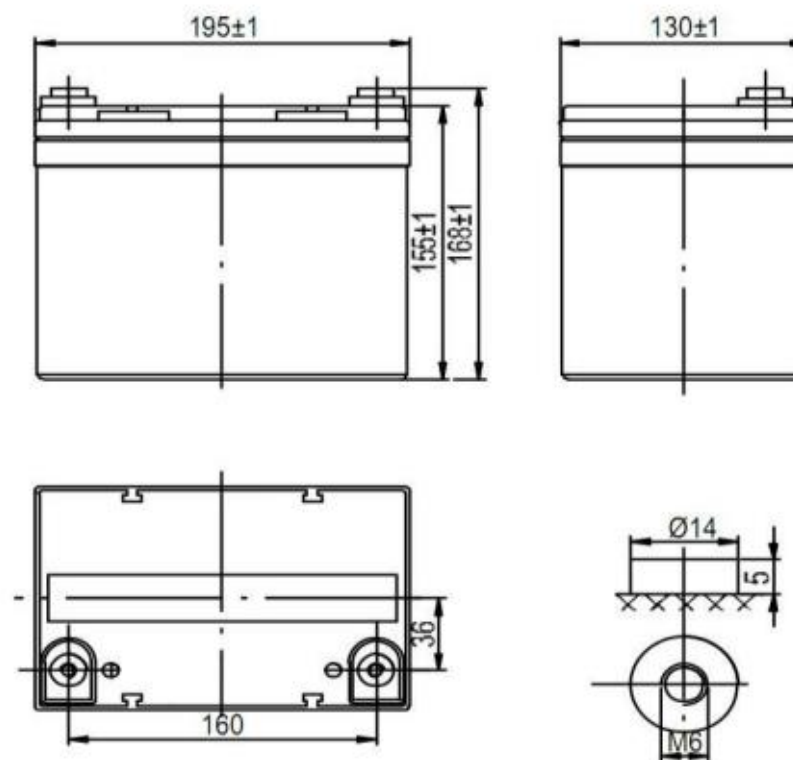

Fig. 7.14. Dimensions of AGM-battery

On the other GTS models are installed lithium-ion batteries with a capacity of 42 A*h. Such a solution has not only a greater power reserve, but also a higher current output, which increases the speed and range of movement.

Table 4. Lithium battery specifications

Nominal voltage	24 V
Rated capacity	42 A*h
Weight	4 kg
Working temperature	-20 ... 60 °C
Charge temperature	0 ... 40 °C
Storage temperature	-20 ... 60 °C
Number of cycles at 40% capacity loss	1000 cycles of full charge/discharge

Replacement and disposal of batteries should only be performed by a qualified technician. If the battery fails, it is replaced completely.

Sequence of operations when removing or installing batteries:

1. Loosen the thumbscrews on the battery module cover and lift the cover up. If the headlights are installed on the cover, you must carefully disconnect the headlight power connector.
2. Disconnect the battery connector.
3. Release the battery from the holder and remove it.

7.7. Charging

NOTIFICATION

Battery discharge. If the battery is completely discharged, the electric wheelchair will stop, which could create a dangerous situation for the user. Therefore, it is necessary to charge the battery on time.

NOTIFICATION

Battery damage. When the battery is completely discharged, it must be charged within 24 hours. When storing a discharged battery for a long time, the battery becomes unusable and must be replaced.

For optimal battery performance, consider the following:

- Batteries can be charged at any time, independently of their state of charge.
- A fully discharged battery takes about 8 hours to charge. The charger should then be disconnected to avoid damage to the battery..
- With daily use wheelchairs is recommended to connect the charger overnight to ensure full capacity of the batteries during the day.
- When the wheelchair is idle for a long time, the batteries discharge. If the wheelchair does not move for a long time, it is recommended to charge the batteries once a month to maintain the performance.
- Avoid completely discharging the battery (completely discharge).

- When charging the battery, switch off the wheelchair control to ensure that the charging current is fully fed to the battery.

When charging batteries, always remember that:

- It is allowed to use only the charger supplied with the Product. Ignoring this rule will void the *Manufacturer's* warranty obligations.

7.8. Battery charger

The battery charger supplied with the GTS series *Products* should not be used to charge other devices as this may damage it.

Use a 220 ± 15 V power supply. Using other power sources may damage both the battery and the battery charger.

The charger is equipped with automatic control of the operating mode and does not require additional control during operation.

Do not use the battery charger near various heat sources and heating elements. If the battery charger overheats (> 70 ° C), sparks, fires, etc. turn it off immediately.

Charging the *Product*:

- Insert the plug of the battery charger into the charging socket located in the center of the front of the *Product*. One red LED on the battery charger will illuminate.
- Insert the plug of the battery charger into the 220V power supply, the second LED will turn red.
- When the battery is fully charged, the second red LED will turn green.
- Disconnect the charger from the *Product*.

8. Movement modes

8.1. Movement “On tracks”

The tracked platform on Caterwil *Products* is designed for stair climbing. Below are instructions to explain how to climb stairs and other obstacles.

ATTENTION

**Descent on the steps is carried out only on tracks and only in front!
Climb is carried out only on tracks and only in reverse!**

ATTENTION

When driving on the stairs, the driver should sit straight, leaning back in the seat. The driver should not tilt the body to the sides and forward this can lead to skewed movement of the wheelchair, tracks slipping, disrupting the work of the wheelchair or falling!

DESCENT

To descend the stairs, you must:

- Drive up to the stairs in front and stop at a distance of at least 10 cm from the first step. The wheelchair should be parallel to the flight of stairs.
- Switch the wheelchair to the "On tracks" mode according to chapter 7. After the wheelchair is completely transferred to the tracks, a signal will sound and the wheelchair will enter the automatic mode of holding the horizontal position.
- Set the minimum speed value (gear) on the remote controller and start moving by pressing the joystick straight forward.
- Descend smoothly and carefully.
- If the wheelchair does not move parallel to the flight of stairs when descending, stop, slowly align the wheelchair with the joystick and continue driving.
- If, due to a skew, the wheelchair has stopped, you should align the position of the wheelchair on the stairs and continue driving.
- Check the position of the wheelchair in relation to the flight of stairs.
- Do not exceed the incline angle of 35 °, if this angle is exceeded by more than 5 °, the automation will block the movement..

CLIMB

To climb stairs, you must:

- Drive up to the stairs in backward and stop at a distance of at least 20 cm from the first step. If you come to the stairs in front, you need to get out, as climbing the stairs is carried out only in reverse. The wheelchair should be parallel to the flight of stairs.
- Switch the wheelchair to the "On tracks" mode according to chapter 7. After the wheelchair is completely transferred to the tracks, a signal will sound and the wheelchair will enter the automatic mode of holding the horizontal position.
- Set the minimum speed value (gear) on the remote controller and start moving by pressing the joystick straight back.
- Descend smoothly and carefully.
- If the wheelchair does not move parallel to the flight of stairs when descending, stop, slowly align the wheelchair with the joystick and continue driving.

8.2. Movement on wheelchair GTS 4WD

ATTENTION

All-wheel drive allows you to climb and descend from obstacles no more than 8 cm high, both when moving forward and in reverse. Before overcoming obstacles, reduce the speed to prevent the Product from overturning.

ALL-WHEEL DRIVE

The main driving modes of the wheelchair GTS 4WD are all-wheel drive. In this mode, all four wheels are driven. Such a design of the drive system allows you to move comfortably both on a flat surface and to overcome sand, snow and even mud.

In this mode, the wheelchair is capable of making a "tank turn". It should be noted that the maneuvering on all four driving wheels create a greater load on the engine. If possible, avoid maneuvering on surfaces with high friction, such as asphalt. This will reduce the wear on the tires and battery consumption.

REAR DRIVE

A special mode in which additional self-turning wheels are extended at the front of the wheelchair. In this case, the front wheels are detached from the surface, but continue to rotate while driving.

In front-wheel drive mode, the wheelchair has the following advantages:

- Speed - the wheelchair does not need to slow down to maneuver, which has a positive effect on linear speed and handling in movement.
- Maneuverability - the small distance between the drive wheels and the additional wheels allows you to make difficult maneuvers and even full turns in the narrow corridors of houses and apartments.
- Economical - maneuvering in the wheelchair with additional wheels does not require additional load to overcome the friction of tires on various types of surfaces during a turn.

Despite the advantages of rear-wheel drive, this mode has a significant lack:

- Passability - the small diameter of the additional wheels does not allow them to overcome obstacles with a height of more than 1 cm. You should carefully choose the way of movement and limit the use of this mode to places with high-quality coverage, for example, asphalt, shopping centers, as well as apartments.

9. Additional options

The *Products* offered by the *Manufacturer* can be additionally equipped with a number of options that are not included in the standard set of the electric wheelchair. Additional options are designed to improve user comfort during operation, for people with problems with maintaining the position of the body, as well as complete or partial dependence.

The installation of options should be carried out by the *Manufacturer* or a specially trained person, since some components of the *Product* are replaced with modified ones with extended functionality and require the removal of standard holders.

Lateral supports

Lateral supports – standard option for people with problems of retention in body position. Their installation requires replacement of the attendant's standard handle holders. Installation is possible only by the *Manufacturer*.



Fig. 9.1. Lateral supports

Rearview mirror

The option is designed for people actively moving on the road, and is also useful when maneuvering in a narrow space and reversing. For installation, additional holder is required under the armrest. The mirror is fixed on the side opposite to the control panel (Fig. 9.2).



Fig. 9.2. Rearview mirror

Additional remote control for the attendant

An additional remote control for the attendant is required in cases of assistance to the user in controlling the wheelchair. All GTS models are equipped with an additional connector in the electronics box for connecting it. The remote control is supplied with an additional holder on the handle of the attendant. The priority of the remotes is determined by the first press after switching on, while the second remote control becomes inactive.



Fig. 9.3. Additional remote control for the attendant

Abductor

The abductor is designed to maintain the correct position of the human body. It is installed on the chair and is located between the legs of the user, it is adjustable back and forward. Installation of the abductor is carried out on special holders in the chair frame. Installation of the abductor is possible only from the *Manufacturer*.



Fig. 9.4. Abductor

Two-point safety belt

The product can be equipped with a two-point belt. The belt is used to provide additional stability to the user in the wheelchair prevents him from falling out.

To fix the user with a belt, it is necessary to insert both halves of the lock into each other (Fig. 9.5), until a characteristic click appears. Then check its tension. The belt is removed by pressing the red button.

Length adjustment of the belt is carried out by pulling the outer part of the belt through the attachment points to the lock. Excess belt length is compensated by a plastic slider.

Improper use of the belt can injure the user. The belt must be properly adjusted and not create strong pressure on the internal organs. In this case, the tension of the belt should ensure a reliable fixation of the human body, excluding its free movement in the chair during movement.



Fig. 9.5. Two-point safety belt

Four-point safety belt

A four-point belt is required for people with problems of retention in body position. This belt allows you to fix not only the lower back, but the thoracic region of the user in the chair, excluding his movement during the use of the *Product*.

The principle of operation of a four-point belt is similar to a two-point belt. However, focus on the position of the upper parts of the belt before use. They should fix the user's shoulders from the outside (see fig. 9.6). Do not use the belt if one or both parts are extended from the user's back.



Fig. 9.6. Four-point safety belt

Roof from sun and rain

The product can be additionally equipped with a special umbrella (fig. 9.7), it protects the user from direct sunlight and atmospheric precipitation such as rain.

The option will be useful for users with high sensitivity and to reduce the possibility of sunstroke or heatstroke.



Fig. 9.7. Roof from sun and rain

High-capacity battery

The range and operating time of the *Product* can be increased by installing a 70 A * h high-capacity battery (Fig. 9.8). Replacing the standard battery with high-capacity battery increase the movement distance up to 40 km.



Fig. 9.8. High-capacity battery

Car charger

The car charger allows you to charge the wheelchair from the car's cigarette lighter (fig. 9.9). For charging, you need to insert one plug of the battery charger into the car's cigarette lighter, the other into the standard charging connector on the wheelchair.



Fig. 9.9. Car charger

10. Safety features

Caterwil GTS *Products* have safety features to provide maximum safety during exploitation, transportation and storage.

Table 5. Safety features

No	Safety feature	Notes
1	Emergency stop button	Activation of the button turns off the power supply, which leads to blocking of the main drives and stopping the wheelchair
2	Electromagnetic brake of main drives	Activated when there is no power supply to the main drives. Provides wheelchair parking
3	Circuit-breaker 63A	Protects against short circuit and system overload
4	Battery indicator	Monitors battery level
5	Emergency stop when remote control is failed	Automatic stop of the wheelchair when the control panel is disconnected or broken
6	Motors load control	If motors are overloaded systems stops automatically
7	Monitor of contact	In case of break or disconnection of cables, the wheelchair will stop automatically and inform the user of the problem.
8	Control of the horizontal position of the wheelchair	The system monitors the tilt position of the wheelchair. If the angle is too large, the wheelchair speed is reduced. At critical tilt angles the <i>Product</i> stops completely

9	Stopping linear actuators	Limit switches are included in the design of linear actuators. When reaching the maximum stroke, they turn off automatically
10	Self-diagnostic system	System checks all the components. If any component does not work, the indicators on the remote control will blink (see Table 6)

11. Fault and troubleshooting

INFORMATION

If the problem cannot be completely resolved using the instructions in this chapter, we recommend that you contact the service center.

Caterwil GTS has a self-diagnosis system that is activated when the electric wheelchair circuit-breaker is turned on and works in real time. If a problem is detected, the check is displayed on the control panel. For a standard remote control, this is realized by the simultaneous blinking of the driving mode ("On tracks" and "On wheels") and a combination of LEDs on the speed mode indicator scale (Fig. 11.1). Depending on the number of blinking LEDs, their combination and location, they correspond to a specific error code (see table 6).

In the event of some faults, the *Product* may continue to move. The fault will negatively affect the function of the electric wheelchair. Until the fault is corrected, the system is not fully operational.

For example, when the drive mode LEDs are blinking and the speed LEDs are on, as shown in Figure 11.1, it means "Overload of the Chair drive".

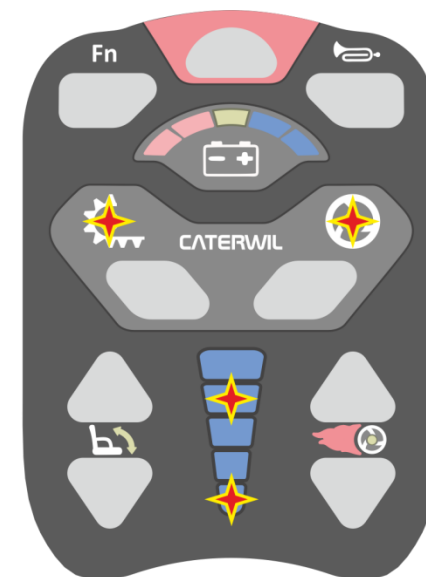

















Fig. 11.1. Example of error indication on a standard remote controller

Table 6. Light indication of error codes. Reasons for appearance and methods of solution.

Error code	Error name	Reason	Solution
	No signal from the Chair angle sensor	Cable of the chair angle sensor are disconnected or damaged	Reconnect the sensor cable and tighten the nut
		Fault of the chair angle sensor	Contact the <i>Manufacturer</i>
		Fault of the electronics box	
	No signal from the Base angle sensor	Fault of the electronics box	Contact the <i>Manufacturer</i>
	Chair or Base angle sensor is incorrectly installed	Cable of the chair angle sensor are disconnected or damaged	Reconnect the sensor cable and tighten the nut
		Error of positioning of the chair angle sensor or electronics box	Fix the sensor in its standard place
		Fault of the chair angle sensor	Contact the <i>Manufacturer</i>
		Fault of the electronics box	
	High inclination of the wheelchair	The wheelchair is turned over	Get off the obstacle
		Wrong electronics box positioning	Fix the electronics box in its standard place
		Fault of the electronics box	Contact the <i>Manufacturer</i>
	Overload of track platform drive	High load on track platform drive	Make sure that there is no obstacle when unfolding the platform. Make sure the weight of the user, including items, is less than 115 kg
		Fault of the track platform drive	Contact the <i>Manufacturer</i>
		Fault of the electronics box	

Error code	Error name	Reason	Solution
	Overload of the Chair drive	High load on chair drive	Make sure that there is no obstacle when unfolding the platform. Make sure the weight of the user, including items, is less than 115 kg. Move deeper and shift your weight onto your back
		Fault of the chair drive	Contact the <i>Manufacturer</i>
		Fault of the electronics box	
	Pressed buttons or joystick when starting the wheelchair	Buttons or joystick are pressed when started	Turn off and on the wheelchair
		Fault of the remote controller	Contact the <i>Manufacturer</i>
	Not connected left brake	Fault of the left brake	Contact the <i>Manufacturer</i>
		Fault of the electronics box	
	Not connected right brake	Fault of the right brake	Contact the <i>Manufacturer</i>
		Fault of the electronics box	
	Main motor overload	High load of main motors	Change your driving style and mode
		Fault of the electronics box	Contact the <i>Manufacturer</i>

Error code	Error name	Reason	Solution
	The joystick is not calibrated	Calibration data is corrupted or not set	Contact the <i>Manufacturer</i>
		Fault of the remote controller	
	No signal from the joystick	Poor contact between remote controller board and joystick	Contact the <i>Manufacturer</i>
		Fault of the joystick	
	No signal from the Main board	Poor contact between remote controller and electronics box	Check the connection between the electronics box and the remote controller
		Fault of the remote controller	Contact the <i>Manufacturer</i>
		Fault of the electronics box	
	Left drive not connected	Left reducer transferred to the idle mode	Turn the gearbox lever, restart the remote controller
		Sensor wire disconnected	Connect the wire and tighten the nuts
		Fault of the sensor	Contact the <i>Manufacturer</i>
	Right drive not connected	Right reducer transferred to the idle mode	Turn the gearbox lever, restart the remote controller
		Sensor wire disconnected	Connect the wire and tighten the nuts
		Fault of the sensor	Contact the <i>Manufacturer</i>

12. Maintenance, cleaning and disinfection

INFORMATION

In case of problems during the maintenance of the *Product*, you should consult a specialist. The electric wheelchair should be checked by a specialist once a year for its operational reliability.

Maintenance intervals

The functionality of the electric wheelchair must be checked before each use. The user must carry out the work shown in table 7 with the specified intervals.

Table 7. Maintenance intervals of the *Product* units

Part of the wheelchair	Actions performed	Before every trip	Weekly	Monthly
Armrests	Armrest height fixing screws are tightened	X	X	X
	The remote controller is fixed and does not move in the holders			
	The armrest is not damaged			
Drive wheels	Wheels should rotate freely and without axial runout		X	X
	Wheelchair moves in a straight line			
Tires	Tire pressure corresponding to the recommended value			X
	Remaining tire tread height not less than 1 mm			X
	No visible damage to tires			X
Batteries	The charge level is sufficient to move along the intended distance	X		
Electronic equipment	The remote controller does not give errors at startup	X		
	All connectors are fixed and do not depart			X
Steering wheels	Wheels rotate freely without beating			X
Seat cover and seat belts	Seat cover is not damaged		X	X
	The belt has no visible defects			X
	The seat belt buckle is locked and unlocked by pressing the button			
Tracks	Tracks are free from oil and dust	X		
Drive chains	The chains are undamaged and free from dirt. Sagging of drive chains no more than 5 mm			X

Maintenance manual

12.1. Drive wheel service

To check wheel attachment:

1. Put the wheelchair in "On tracks" mode.
2. Tighten all four screws with an 8mm Allen key.

To check the pressure in the wheel:

1. Unscrew the cap from the chamber nipple.
2. Using a manometer or a pump equipped with a manometer, check the tire pressure.
3. The tire pressure should be 2.5 ... 3 atm. If the pressure differs from this value, then correct it to the required.



Fig. 12.1. Tightening the drive wheel screws

12.2. Steering wheel service

To check the condition of the wheel:

1. Put the wheelchair in "On tracks" mode.
2. Check the condition of the mechanism with your hands and make sure there are no beats.
3. Check the tires as well as the axle bearings of the wheel. The wheel should not have any runout during rotation. The rotation must be free.
4. Use a manometer to check the pressure in the wheel.



Fig. 12.2. Tightening the driven wheel axle

12.3. Tensioning the tracks

To tighten the track, you need:

1. Loosen the axis of the track tensioning roller (Fig. 12.3, 1) Allen key 8 mm and 17 mm wrench.
2. Using a 13 mm key, loosen the locknuts (Fig. 12.3, 2) and make a few turns.
3. Using a 4 mm Allen key, screw in the tensioner screws (Fig. 12.3, 3) by the same number of turns (for left and right tracks).
4. Tighten the locknuts.
5. Tighten the tensioner roller axle with normal torque.

The track must be tightened so that it does not slip on the pulley and rails.

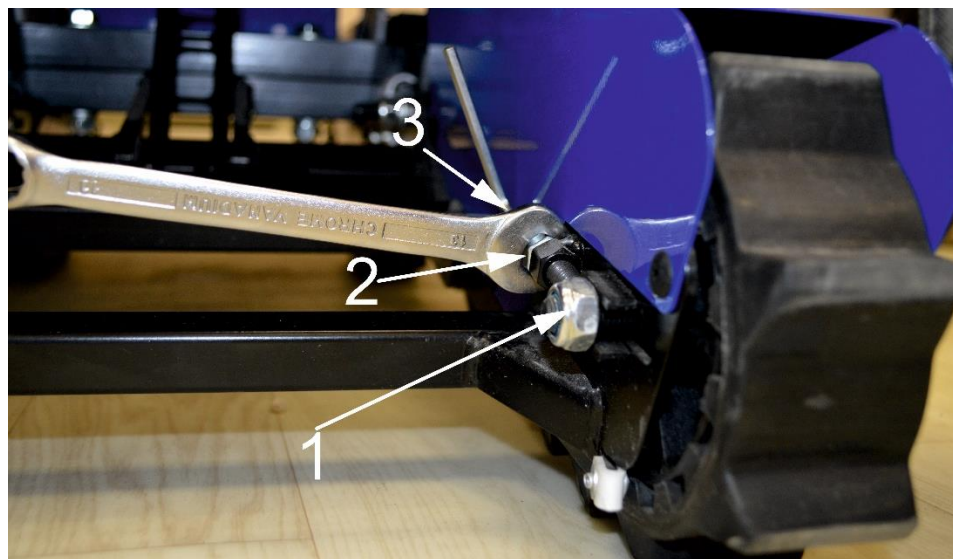

Fig. 12.3. Tensioning the tracks

12.4. Chain lubrication

The lubrication on the drive chains loses its properties when mixed with road dust. Additional lubrication is required with use.

Clean the chain with paper towels before renewing the lubricant. Then the wheelchair is transferred to the "On tracks" mode and lubrication is applied in any way to the inner surface of the chain. Clean the chain with paper towels before renewing the lubricant. Then the wheelchair is switched to the "On tracks" mode and the inner surface of the chain is coated with grease in any way. To distribute the lubricant to all the links of the chain, drive a short distance on the wheelchair and lubricate again. To obtain the greatest effect, the operation of lubricating and moving (in any mode) the wheelchair should be carried out several times.

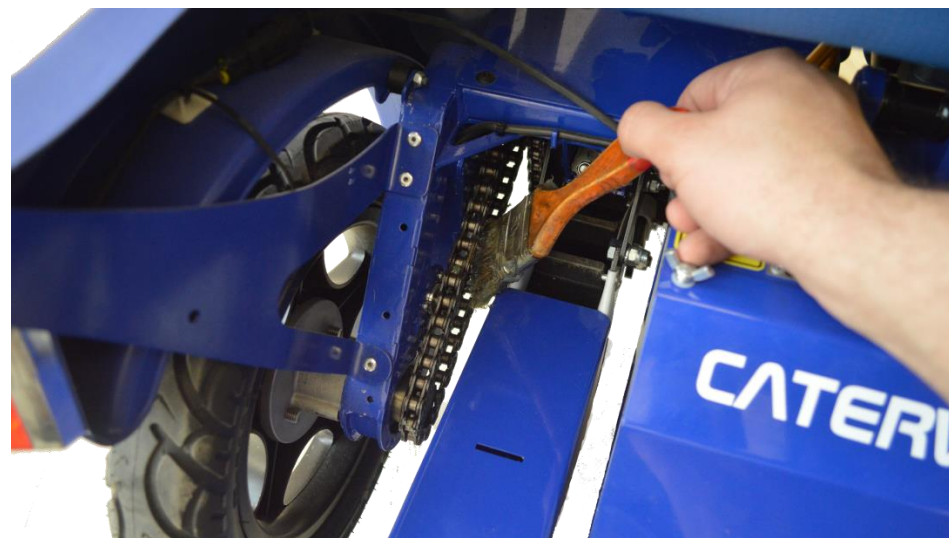

Fig. 12.4. Chain lubrication

12.5. Cleaning

NOTIFICATION

Damage to electronic equipment due to water enter. When cleaning the Product, avoid contact of electronic components, motors and batteries with water, as this can cause faults.

NOTIFICATION

Damage to the components of the Product. When cleaning the electric wheelchair, do not use aggressive cleaning agents or solvents. Do not use pressurized water devices to clean the wheelchair.

Depending on the intensity of use and the degree of soiling, the electric wheelchair should be cleaned regularly.

Use a damp cloth and mild cleaning solution to clean the remote controller, armrests, footrests, seat and frame.

Clean the wheels and tracks of the wheelchair with a damp cloth.

13. Legal Notice

13.1. Service life

After the expiration of the warranty period, the user can continue to use the Product. The service life of the wheelchair set by the Manufacturer is 5 years, with timely service and maintenance, use of the Product for its intended purpose in accordance with all the requirements and recommendations given in this manual. The storage time of the Product in a specialized store or in a service organization for the disabled is not included in the service life.

It should be noted that with constant care and maintenance, the operation of the *Product* will be reliable even after the expiration of the service life set by the *Manufacturer*.

13.2. Responsibility

The manufacturer is responsible for the *Product* only if it is used in the specified conditions and in accordance with its intended purpose. The manufacturer recommends to use the *Product* properly, to carry out its care and maintenance in accordance with the instructions.

The manufacturer is not responsible for damage caused by the use of components and spare parts from other *Manufacturers*. Repairs may only be carried out by specialized service centers or by the *Manufacturer*.

13.3. Warranty conditions

The manufacturer warrants that the stair-climbing wheelchair Caterwil GTS is respect to the requirements of regulatory documents (Technical Specifications 30.92.20-009-23551694-2019) when properly transported and used.

To maintain the warranty for the Product, you must follow the rules described in this manual.

Buy the wheelchair only from an authorized dealer or Manufacturer. Please refer to this manual during operation. Carry out maintenance in specialized service centers.

13.4. Warranty obligations

- a) The gearbox is subject to one month's warranty replacement and one year's warranty repair.
- b) The remote controller is subject to a three-month warranty replacement and the electrical system is subject to a one-year warranty.
- c) The battery is subject to a four-month warranty replacement if its capacity is less than 60% of the nominal.
- d) The frame is subject to warranty replacement within one year if it is severely deformed or welded joints are broken.
- e) Tires, tracks, seat and other similar items are not subject to warranty replacement.

The warranty is provided from the date of purchase of the Product.

The warranty is canceled in cases:

- a) Failure to follow this instruction.
- b) Carrying out repairs not at authorized service centers.
- b) Use of spare parts and elements from other manufacturers.
- d) End of the warranty period.

14. Warranty card

1. The date of purchase is marked by the seller in the warranty card.

2. If a fault is found in the *Product* during the warranty period, the buyer can contact the seller for repair.

Serial number: _____

Manufacturing date: _____

Date of sale: _____

Caterwil LLC

Phone: **+7-(383)-312-1632**

Address: 4 Lugovaya st., 3 building, 4 part, Skolkovo Innovation center,
Moscow, 143026, Russia

www.caterwil.ru

Seller's signature _____

Buyer's signature _____