



MADE TO MEASURE
PRESCRIPTION FORM

BSK02 - BSKT02

NAME		HOME ADDRESS
EMAIL		
PHONE NUMBER		
FRAME MATERIAL	TICK	
ALUMINIUM		
TITANIUM		



CLASSIFICATION RULES

The maximum height of the seat with or without cushion is:
630 mm for a player between 1.0 and 3.0
580 mm for a player between 3.5 and 4.5

WWW.RMASPORT.COM
+44 1656 674488
SALES@RMASPORT.COM

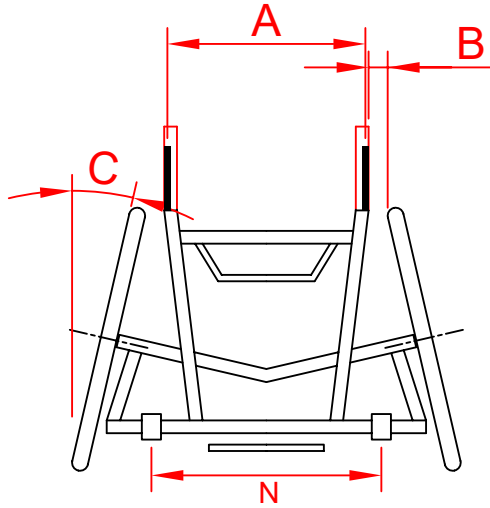

Standard Style Frame

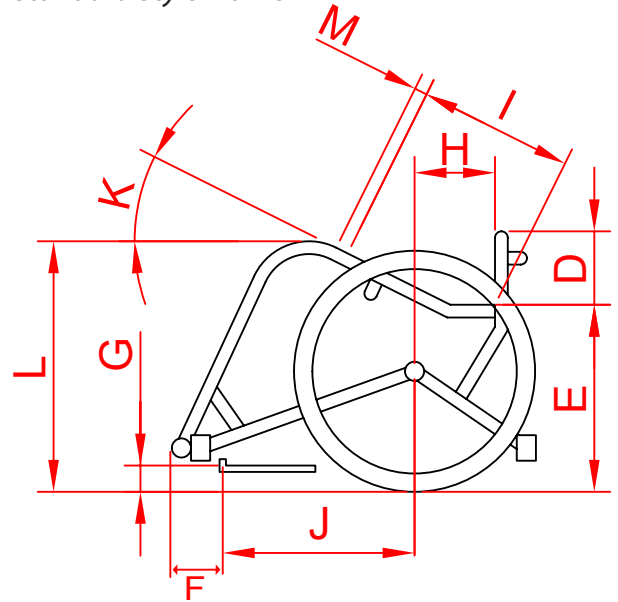

Transfer Style Frame

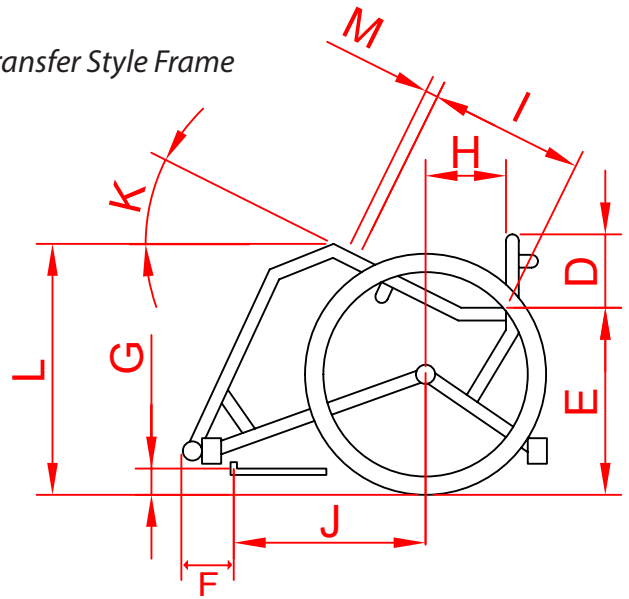

NOTES & DRAWINGS

A. Seat Width Between Arms	<input type="text"/>
B. Wheel to Side Guard	<input type="text"/>
C. Wheel Camber	<input type="text"/>
D. Backrest Height	<input type="text"/>
E. Seat to Floor	<input type="text"/>
F. Axle to Castor	<input type="text"/>
G. Footrest Height from Floor	<input type="text"/>

H. Axle from Backrest	<input type="text"/>
I. Seat Length (Cushion)	<input type="text"/>
J. Axle to Footrest	<input type="text"/>
K. Seat Camber	<input type="text"/>
L. Frame Height at Front	<input type="text"/>
M. Seat Cushion To Bend	<input type="text"/>
N. Front Castor Position	<input type="text"/>
Backrest Angle	<input type="text"/>

WHEEL SET UP (WHEELS & TYRES)

WHEELS - 24"

24" WHEEL OPTIONS	PART NO.	TICK
24" SPINERGY SLX (1/2 AXLE)	SLX-24-24-111	

24" SPECIAL ORDER	TICK

WHEELS - 25"

25" WHEEL OPTIONS	PART NO.	TICK
25" SPINERGY SLX (1/2 AXLE)	SLX-25-24-111	

25" SPECIAL ORDER	TICK

WHEELS - 26"

26" WHEEL OPTIONS	PART NO.	TICK
26" SPINERGY SLX (1/2 AXLE)	SLX-26-24-111	

26" SPECIAL ORDER	TICK

WHEELS - 700C

700C WHEEL OPTIONS	PART NO.	TICK
700C SPINERGY SLX (1/2 AXLE)	SLX-27-24-111	

700C SPECIAL ORDER	TICK

FRAME

SEAT RAKE	PART NO.	TICK
STRAIGHT SEAT		
ERGONOMIC SEAT (upcharge)	RUG/ERGO	

SEAT OPTIONS	PART NO.	TICK
STANDARD SEAT SLING		
ALUMINIUM PLATE (upcharge)		

ANTI-TIP OPTION	PART NO.	TICK
FIXED ANTI-TIP		
ADJUSTABLE ANTI-TIP (upcharge)		

ANTI-TIP OPTION	PART NO.	TICK
SINGLE ANTI-TIP		
DOUBLE ANTI-TIP (upcharge)		

CASTOR WHEELS	PART NO.	TICK
STANDARD - BLACK (72mm)		
LABEDA - GREY (72mm) (upcharge)	WH0114	
LABEDA - ORANGE (72mm) (upcharge)	WH0113	
LABEDA - WHITE (72mm) (upcharge)	WH0112	

TYRES - 24"

24" TYRE OPTIONS	PART NO.	TICK
KENDA KONCEPT RED	WH0057	
SCHWALBE (GREY & BLACK)	WH0069	
SCHWALBE (RED & BLACK)	WH0107	
TUFO TUBELESS (upcharge)	WH0119	

TYRES - 25"

25" TYRE OPTIONS	PART NO.	TICK
KENDA KONCEPT RED	WH0087	
SCHWALBE (GREY & BLACK)	WH0070	
TUFO TUBELESS (upcharge)	WH0126	

TYRES - 26"

26" TYRE OPTIONS	PART NO.	TICK
KENDA KONCEPT RED		
SCHWALBE (GREY & BLACK)		
SCHWALBE (RED & BLACK)		
TUFO TUBELESS (upcharge)		

TYRES - 700C

700C TYRE OPTIONS	PART NO.	TICK
KENDA KONCEPT RED		
SCHWALBE (GREY & BLACK)		
TUFO TUBELESS (upcharge)		

TRANSFER BAR	PART NO.	TICK
NO TRANSFER BAR		
TRANSFER BAR (SEE CHAIR DRAWING)		

FOOTREST STYLE	PART NO.	TICK
ADJUSTABLE - ALUMINIUM		
FIXED - ALUMINIUM (upcharge) /FFR		
ADJUSTABLE - CARBON (upcharge) /AFRC		
FIXED - CARBON (upcharge) /FFRC		

Carbon Fibre footplates are flat plate only

FOOTREST ANGLE	PART NO.	TICK
FLAT - 0 degree		
CUSTOM -		

FRAME COLOUR OPTIONS

FRAME COLOURS (FoC)	PART	COL	TICK
TEXTURED BLACK	FXPE 8005		
MATTE BLACK	9005 M		
GLOSS BLACK	FXPE 7003		
WHITE GLOSS	9016G		
MELOW YELLOW	1028		
COBALT BLUE	5013		
LIGHT GREEN	6027		
RED LILAC	4001		
BLUE LILAC	4005		
TRAFFIC PURPLE	4006		
SKY BLUE	5015		
TRAFFIC BLUE	5017		
RED	3028S		
TRAFFIC RED	3020		
PASTEL BLUE	5024		
YELLOW GLOSS	1017G		
SIGNAL YELLOW	1003		
WATER BLUE	5021		
GREY	7024G		
TELEGRAY	7047		
PASTEL ORANGE	2003		
LIGHT IVORY	1015		

SPECIAL COLOURS	PART	PRICE	COLOUR	TICK
IRIS GREEN	BS12E53	POA		
PANTONE BLUE	274C	POA		
PANTONE GREY 9	PECOOL G 9	POA		
PANTONE RED	186C	POA		
ORIENT RED	3031	POA		
CHROME PAINTED	FXEP6003	POA		
HEATHER VIOLET	PG 4003	POA		
ULTIMATE CANDY RED	FXPE004-9008	POA		
IRIDECENCE LARVA	FXPE000-7007	POA		
IRIDECENCE DREAM	FXPE000-7002	POA		
ULTIMATE CANDY ORANGE	FXPE004-9003	POA		
FLORESCENT YELLOW	FXPE003-4004	POA		
BLACK BRONZE	FXPE000-7008	POA		

LACQUER FRAME	PART	PRICE	TICK
CLEAR MATTE	FXPE 5003	POA	
CLEAR GLOSS	FXPE 5002	POA	
WHITE HIGH FLOW PRIMER	FXPE 3001	POA	
HOLOGRAPHIC STAR LACQUER	FXPE8010	POA	
LILAC STAR GLOSS	FXPE 8007	POA	
CANDY YELLOW GOLD	FXPE 9018	POA	
WHITE STAR POWER	FXPE 020 8003	POA	

I.....

AM SOLELY RESPONSIBLE FOR ALL SUPPLIES MEASUREMENTS AND GIVE FULL CONSENT FOR RMA SPORT TO PROCEED WITH THE MANUFACTURING OF THIS CHAIR,

SIGNED.....

DATE

