

## CONTENTS

<b>1. CODES.....</b>	<b>PAG.3</b>
<b>2. INTRODUCTION.....</b>	<b>PAG.3</b>
<b>3. INTENDED USE.....</b>	<b>PAG.3</b>
<b>4. EU DECLARATION OF CONFORMITY .....</b>	<b>PAG.4</b>
<b>5. WARNINGS .....</b>	<b>PAG.4</b>
5.1 Warnings on use .....	pag. 4
<b>6. SYMBOLS USED .....</b>	<b>PAG.5</b>
<b>7. BEFORE EVERY USE.....</b>	<b>PAG.5</b>
<b>8. VIEW OF THE PARTS AND ASSEMBLY .....</b>	<b>PAG.6</b>
8.1 View of the parts RP955 .....	pag. 6
<b>9. TECHNICAL SPECIFICATIONS .....</b>	<b>PAG.12</b>
<b>10. DECLARATION OF ELECTROMAGNETIC COMPATIBILITY (ONLY FOR RP951 RP958) .....</b>	<b>PAG.13</b>
<b>11. MAINTENANCE .....</b>	<b>PAG.14</b>
<b>12. CLEANING AND DISINFECTION.....</b>	<b>PAG.14</b>
12.1 Cleaning.....	pag. 14
12.2 Disinfection .....	pag. 14
<b>13. DISPOSAL CONDITIONS .....</b>	<b>PAG.14</b>
<b>14. WARRANTY .....</b>	<b>PAG.14</b>
<b>15. REPAIRS .....</b>	<b>PAG.15</b>
15.1 Repairs under warranty.....	pag. 15
15.2 Repairing a product not covered by the warranty .....	pag. 15
15.3 Non-defective products.....	pag. 15
<b>16. SPARE PARTS.....</b>	<b>PAG.15</b>
<b>17. NON-LIABILITY CLAUSES.....</b>	<b>PAG.15</b>

## 1. CODES

- RP955 Easy access exercise bike  
RP956 Recumbent exercise bike

**N.B.:** Check to ensure that no parts of the product have been damaged during shipment. Do not use the product if it is damaged and contact the retailer for further instructions.

EN

## 2. INTRODUCTION

Thank you for choosing a **device from the MOPEDIA line** manufactured by **MORETTI S.p.A.** Carefully designed and manufactured to the highest quality standards, this device guarantees **optimal comfort, advanced safety, and long-term reliability**, making it ideal for effectively and practically meeting the needs of users and operators and for use in the home and healthcare settings.

### This manual provides:

- Detailed instructions for the correct use of the device;
- Useful information for proper maintenance;
- Essential recommendations to ensure the safety of the user and staff.

**Important!** Please read the entire manual carefully before using the device. If you have any questions or need further clarification, please contact your trusted dealer or the authorized **MORETTI S.p.A.** technical support service.

### WARNING!



- Do not use the product for any purpose other than that specified in this manual.
- Moretti S.p.A. declines any and all liability for damages resulting from improper use of the device or any use other than the one specified in this manual.
- The manufacturer reserves the right to modify the device and its relevant manual without prior notice, in order to improve the product's features.

## 3. INTENDED USE

### 3.1 Intended use

MOPEDIA exercise bikes are devices intended for training people with partial or temporary disabilities in institutions, healthcare facilities, or at home.

### 3.2 Application environment

MOPEDIA exercise bikes can be used in medical facilities such as nursing homes, rehabilitation centers, and geriatric centers and/or in the home as defined in UNI EN ISO 20957-1 and 20957-5 standards.

### 3.3 Warning

#### CAUTION



- It is forbidden to use this device for purposes other than those defined in this manual.
- Moretti S.p.A. declines all responsibility for damage resulting from improper use of the device or use other than that indicated in this manual.
- The manufacturer reserves the right to make changes to the device and this manual without prior notice in order to improve its characteristics.

### 3.4 Unauthorized use

Any use that deviates from the intended use and may therefore pose a hazard.

For example:

- The load on the device exceeds the maximum capacity.
- Attempting to move the hospital bed while it is in the braked position.
- Using the device on a non-horizontal surface.

#### 4. EU DECLARATION OF CONFORMITY

MORETTI SpA declares, under its own exclusive responsibility, that the products manufactured and sold by MORETTI SpA in the REHABILITATION PEDAL EXERCISER product family conform with the applicable provisions of Regulation (EU) 2017/745 of 5 April 2017 on MEDICAL DEVICES.

To this end, MORETTI SpA guarantees and declares as follows, under its own exclusive responsibility:

1. The devices in question satisfy the general safety and performance requirements set out in Annex I to Regulation (EU) 2017/745, as prescribed by Annex IV to said regulation.
2. The devices in question ARE NOT MEASUREMENT INSTRUMENTS.
3. The devices in question ARE NOT INTENDED FOR CLINICAL INVESTIGATIONS.
4. The devices in question are sold in NON-STERILE packing.
5. The devices in question should be considered as belonging to class I, in accordance with the rules set out in Annex VIII to said regulation.
6. MORETTI SpA maintains and provides to the competent authorities, for at least ten years from the date of manufacture of the last production lot, the technical documentation proving conformity with Regulation (EU) 2017/745.

**N.B.:** The complete product codes, the manufacturer's single registration number (SRN), the basic UDI-DI code and any references to standards used are indicated in the EU Declaration of Conformity that MORETTI SPA issues and provides through its own channels.

#### 5. WARNINGS

- Always consult your doctor or therapist for correct use of the device.
- Keep the packaged product away from sources of heat, as the packaging is cardboard.
- The useful lifetime of the device depends on wear and tear of non-repairable and/or non-replaceable parts and is no longer than 10 years.
- The user and/or patient must report any serious incident that has occurred in relation to the device to the manufacturer and to the competent authority of the Member State in which the user and/or patient is established.

##### WARNING!

For safe use, carefully follow the instructions below:



- The equipment must have at least 60 cm of free space on the sides for access to the exercise position
- Always take extreme care in the presence of moving parts that could trap limbs and cause injury
- Do not allow children unsupervised access to the device





##### 5.1 Warnings on use

- The support bases must be in contact with a flat surface at all times during use, in order to guarantee correct balancing of the device and maximum safety.
- Do not use the device if it is damaged. Risk of accident!
- Unauthorised changes to the pedal exerciser or the use of non-original spare parts could change the structure of the product and create hazardous conditions, which could cause serious damage and void the warranty.
- The product is subject to particular strain that depends on the quality of use and the user's weight. That is why we recommend periodically checking for damage every 3 or 4 months, particularly if it has been subjected to impacts or unnatural stresses due to its use.

##### WARNING!

You should be aware of the signs your own body is sending you. Incorrect or excessive physical activity can be harmful to your health. Stop exercising if you experience one of the following symptoms: pain, tightness in the chest, irregular heartbeat, breathlessness, light-headedness, dizziness or nausea. If one of these conditions occurs, seek medical device before continuing with the exercise program.

6. SYMBOLS USED

	Product code
	Device unique identifier
	CE marking
	Manufacturer
	Production lot
	Read the instruction manual
	Medical Device
	Disposal conditions
	Warning
	Production date
	Disposal of the product according to Directive EC/19/2012
<b>IP20</b>	Protection against dust and water spray
	Type B applied part
	Maximum supported weight

7. BEFORE EVERY USE

- Always check for wear and tear of moving mechanical parts, in order to ensure that the device can be used in total safety for both people and property.
- Check correct assembly of the device, particularly locking of the pedals and their correct insertion
- Always check that the brake for adjusting the exertion intensity is working properly
- Ensure that the screws are completely tightened before use
- Position the product to ensure that it is stable and on a flat surface, away from rugs or similar items
- Check that the electrical parts and power cables are undamaged
- Ensure that you are physically capable of using the device
- Ensure that you are wearing the right clothing for the activity
- Always wear shoes or socks suitable for leg exercises

 **WARNING!**  
Always consult your doctor or therapist before undertaking any rehabilitation therapy.

 **WARNING!**  
Regular maintenance must be performed on the device and it must be checked on a daily basis in order to operate correctly. It is recommended to replace worn or broken parts immediately, as they could cause damage to the patient. It is advisable for an expert to show the patient how to use the pedal exerciser, inviting the patient to repeat the necessary operations several times under the expert's supervision. The correct posture must be maintained for correct rehabilitation. Consult your doctor/therapist before starting the activity.

 **WARNING!**  
Failure to comply with the indications could cause injury or serious health problems.

## 8. VIEW OF THE PARTS AND ASSEMBLY

### 8.1 View of the parts RP955

EN

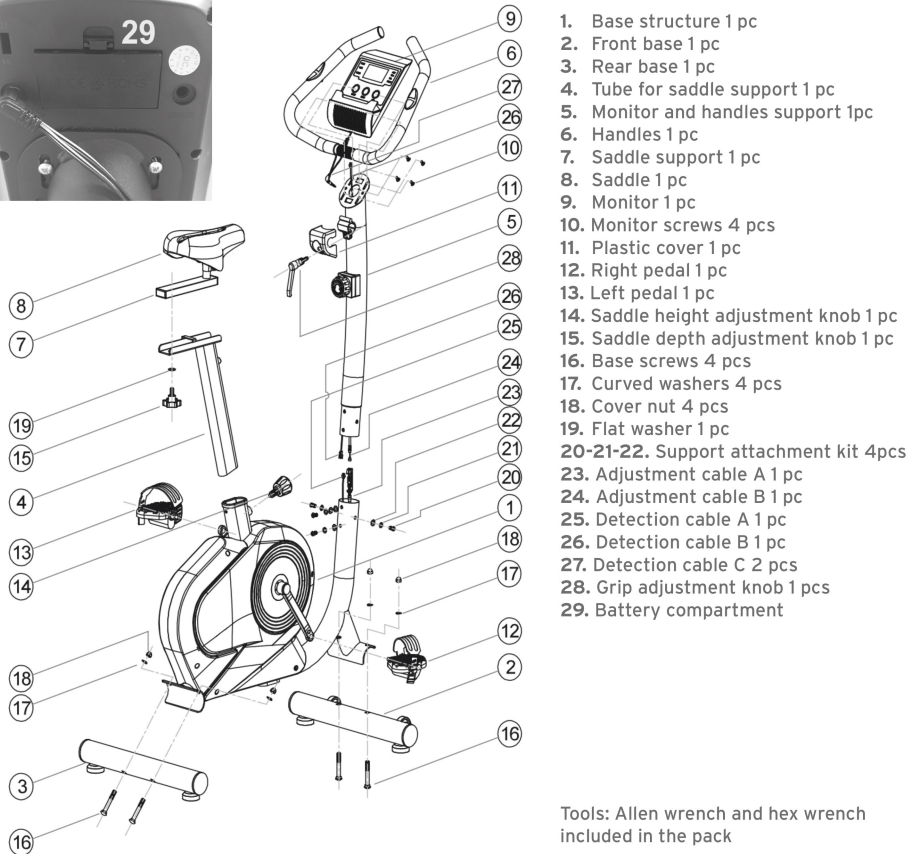

Tools: Allen wrench and hex wrench included in the pack

#### 8.1.1 Assembly

1. Assemble the front base (with wheels) and the rear base (2 and 3) on the base structure (1), attach to the main body (1) using the screws (16), curved washers (17) and cover nuts (18).
2. Install the right pedal and left pedal (12 and 13), marked R for right and L for left, on the base structure (1), then tighten the right pedal clockwise and the left pedal anticlockwise.
3. Position the adjustment knob (14) in the housing, without tightening it completely.
4. Insert the saddle support tube (4) into the housing, then lift the knob and allow the tube to slide until it is locked into place.
5. Place the monitor and handles support column (5) close to the cable outlet tube on the base structure and connect the cables as follows:
  6. Adjustment cable A1 (23) with adjustment cable B1 (24).
  7. Connect detection cable A1 (25) with detection cable B2 (26).
8. Position the support column (5) in the hole on the base structure frame, in the direction indicated in the figure, align the holes and attach it firmly with the support attachment kit (20+21+22).

**N.B.:** You can extract the adjustment knob (14) to adjust the height of the saddle post (4) or the grip post (5).

Illustrative images

9. Position the saddle in the support (4) and attach it with the adjustment knob (15), together with the flat washer (19).
10. Position the handles (6) at the installation point on the column, attach the plastic cover (11) and use the adjustment knob of the grip (28) to attach the entire system firmly.
11. Connect the monitor detection wire (9) to the detection cable B (26) as shown in the figure, then insert detection cable C (27) into the detection cable plug on the back of the monitor
12. Position the monitor (9) on the attachment plate of the column (5), pass the detection cable (26) through the round hole at the centre and secure it using the 4 attachment screws (10).

8.1.2 Use:

**WARNING!**  
 The heart rate detection systems might not be accurate. If you feel faint or unwell, stop exercising immediately

**N.B.:** Before getting onto the exercise bike, position the saddle at the minimum height, in order to identify the best position and to become familiar with the bike, then adjust the height and depth accordingly.

1. Position the exercise bike on a stable surface with good friction
2. Check that the batteries are correctly inserted
3. Adjust the intensity of resistance to the minimum to start
4. Insert your feet in the pedals and start pedalling, gradually increasing the intensity up to the desired speed
5. After around 5 pedal rotations, the display will switch on and it will be possible to use the programming interface
6. To detect heart rate, your hands must remain constantly on the detectors positioned on the handles

**N.B.:** THE DISTANCE between seat and handles can be adjusted from a minimum of 42 cm to a maximum of 48 cm

8.1.3 Display function

1. Automatic scanning (SCAN): in this state, all the TIME-SPD-DIST-CAL-ODO-PUL functions will be sequentially displayed on the main display.
2. Movement time (TIME): cumulative calculation of the movement time from 00:00 to 99:59; the user can push the button to select the display status of the time value.
3. Movement distance (DIST): cumulative calculation of the movement time from 0.0 to 999.9; the user can press the button to select the distance display value.
4. Calories (CAL): shows cumulative burning of calories from 0.0 to 9999. Press the button to select the value displayed. N.B.: this is approximative data only and cannot be used for medical treatment.
5. Movement speed (SPEED): shows the current speed, within a range of 0.0-999.9 km/miles per hour.
6. Odometer (ODO): the maximum measurable distance is 0-9999 km.
7. Pulse (PUL): instantaneous heart rate, 40-240 times per minute.

**N.B.:** This is approximative data only and cannot be used for medical treatment.

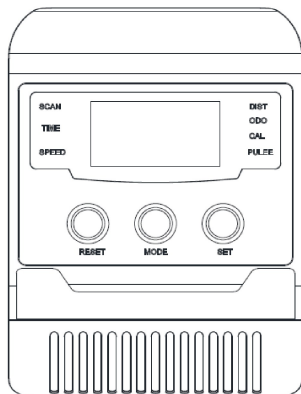

- Pulsante MODE: premendolo è possibile visualizzare tutte le funzioni sequenzialmente
- Pulsante RESET: premendolo resetta singolarmente ogni dato di progresso di allenamento per le funzioni TIME CAL e ODO; tenendolo premuto per 3 secondi le resetta tutte
- Pulsante SET: permette di impostare gli obiettivi di allenamento per le funzioni TIM, CAL e ODO

## 8.2 View of the parts RP956

EN

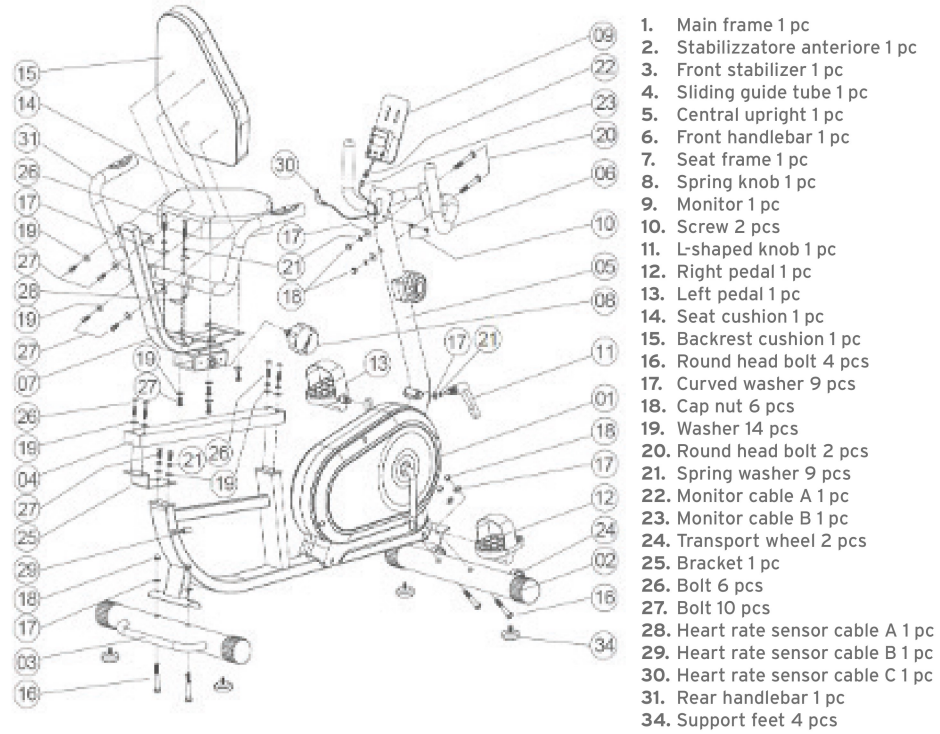

Tools: Allen wrench and hex wrench included in the pack

## 8.2.1 Assembly

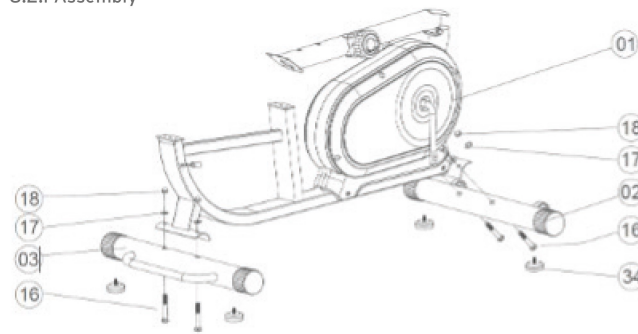

(Pic.1)

1. Assemble the front and rear stabilisers using the screws, washers and nuts (n°. 16, 17 and 18) as shown in pic 1. Then screw the support feet n°. 34 to the stabilisers;

Illustrative images

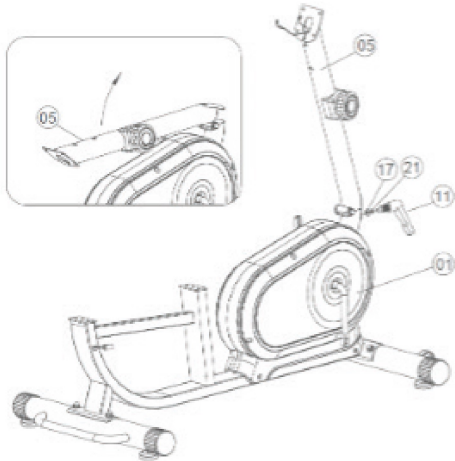

(Pic.2)

2. Lift the central tube no. 05 and secure it using the L-shaped knob n° 11 and washers no. 21 and 17;

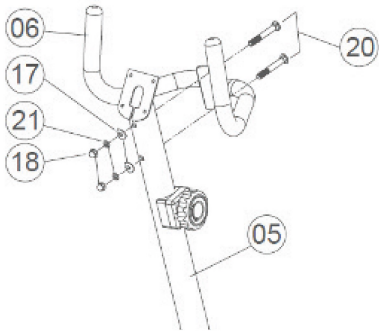

(Pic.3)

3. Assemble the front handlebar using screws n° 20, washers and nuts n° 17, 21 and 18, as shown in pic 3;

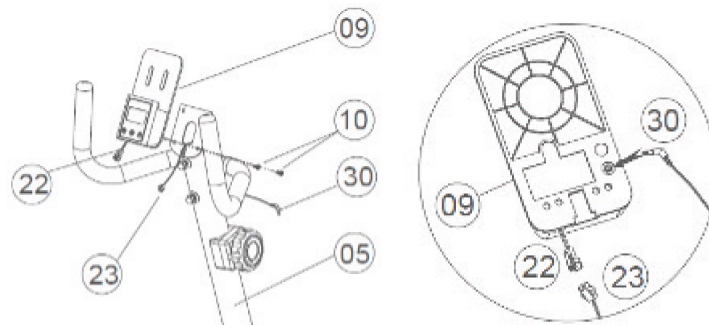

(Pic.4)

4. Assemble monitor n° 09 by first connecting cables n° 22 and 30, then screw it to the structure using screws n° 10 as shown in pic 4;

Illustrative images

EN

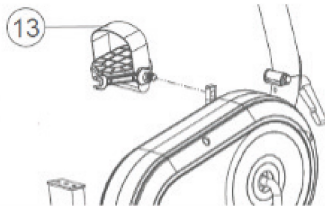

(Pic.5)

5. Assemble pedals n° 13, taking care to respect the right (R) and left (L) sides indicated on the pedals themselves, as shown in pic 5.

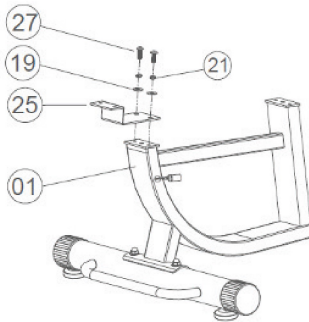

(Pic.6)

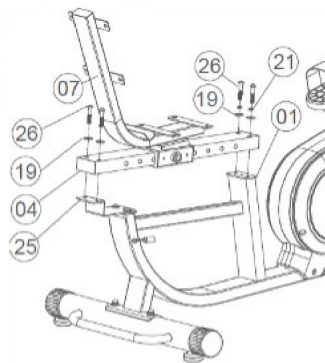

(Pic.7)

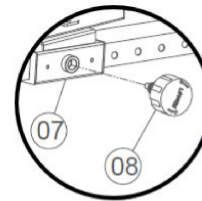

(Pic.8)

6. Assemble bracket n° 25 to the structure using screws n° 27 and washers 19 and 21 as shown in pic 6. Assemble the seat support by inserting the sliding guide tube no. 04 into the seat frame no. 07, then screw the parts to the main structure using screws no. 26 and washers no. 21 and 19 as shown in pic 7. Secure the sliding frame no. 07 by screwing the spring knob no. 08 into the side hole, as shown in pic 8.

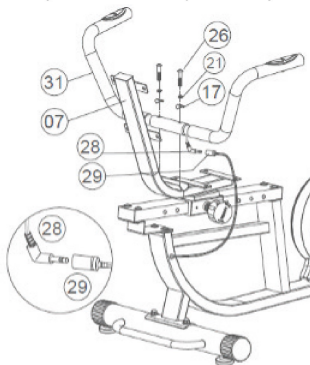

(Pic.9)

7. Assemble the Handle n°31 to the seat frame using screws n°26 and washers n° 17 and 21, then connect cables n° 28 and 29 as shown in pic X.

Illustrative images

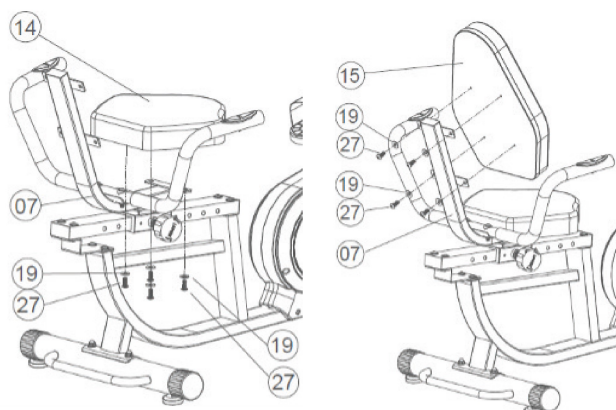

(Pic.10)

(Pic.11)

8. Assemble seat n° 14 using screws n° 27 and washers n° 19, and backrest n° 15 using screws n° 27 and washers n° 19 as shown in pics. 10 and 11.

8.1.2 Use:

**WARNING!**  
 The heart rate detection systems might not be accurate. If you feel faint or unwell, stop exercising immediately

N.B.: Before getting onto the exercise bike, position the saddle at the minimum height, in order to identify the best position and to become familiar with the bike, then adjust the height and depth accordingly.

1. Position the exercise bike on a stable surface with good friction
2. Check that the batteries are correctly inserted
3. Adjust the intensity of resistance to the minimum to start
4. Insert your feet in the pedals and start pedalling, gradually increasing the intensity up to the desired speed
5. After around 5 pedal rotations, the display will switch on and it will be possible to use the programming interface
6. To detect heart rate, your hands must remain constantly on the detectors positioned on the handles

N.B.: The distance between seat and handles can be adjusted from a minimum of 42 cm to a maximum of 48 cm

8.1.3 Display function

1. Automatic scanning (SCAN): in this state, all the TIME-SPD-DIST-CAL-ODO-PUL functions will be sequentially displayed on the main display.
2. Movement time (TIME): cumulative calculation of the movement time from 00:00 to 99:59; the user can push the button to select the display status of the time value.
3. Movement distance (DIST): cumulative calculation of the movement time from 0.0 to 999.9; the user can press the button to select the distance display value.
4. Calories (CAL): shows cumulative burning of calories from 0.0 to 9999. Press the button to select the value displayed. N.B.: this is approximative data only and cannot be used for medical treatment.
5. Movement speed (SPEED): shows the current speed, within a range of 0.0-999.9 km/miles per hour.
6. Odometer (ODO): the maximum measurable distance is 0-9999 km.
7. Pulse (PUL): instantaneous heart rate, 40-240 times per minute.

**N.B.:** This is approximative data only and cannot be used for medical treatment.



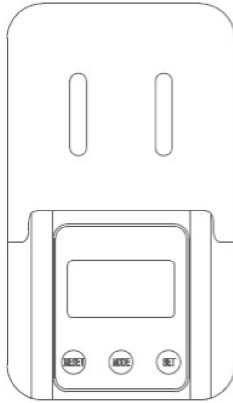

EN



- MODE button: press to display all the functions in sequence
- RESET button: press to reset individually each piece of exercise progress data for the TIME CAL and ODO functions; keep pressed down for 3 seconds to reset all of them
- SET button: use to set exercise targets for the TIM, CAL and ODO functions

## 9. TECHNICAL SPECIFICATIONS

### Dimensions and weight

Codes	 L:	 D:	 H:	H seat from ground	 Kg	
RP955	98 cm	48 cm	128 cm	80-97 cm	25 kg	150 kg
RP956	122-142 cm	58 cm	110 cm	51 cm	24 kg	120 KG

### Technical specifications

Codes	Power supply	Resistances	Exercise	Use and accuracy class (ISO 20957-1 20957-5)	Braking system
RP955	AAA batteries	Iron wheel 5 kg	Active	I B	Independent from speed
RP956	AAA batteries	Iron wheel 3 kg	Active	I B	

**N.B.:** All the products present in this manual have been tested in accordance with standards UNI EN ISO 20957-1 and 20957-5.

#### 9.1 Use and accuracy class

Standards UNI EN ISO 20957-1 and 20957-5 respectively establish the use classes (I S H) and the accuracy classes (A B C) of the exercise devices in this manual. The use class establishes the area of application (at home or in a specialised facility) and the intended use of a device (private use or professional use). In this case, class I, with which all our devices are compliant, indicates that they are intended for professional use in specialised facilities; the accuracy class (A high, B medium and C low), establishes the level of precision for devices that have data collection systems.

**N.B.:** Devices with accuracy class B and C are not suitable for purposes that require a high level of accuracy



#### WARNING!

Use of pedal exercisers at home is only permitted under the direct supervision of a specialist

Illustrative images

**10. DECLARATION OF ELECTROMAGNETIC COMPATIBILITY (ONLY FOR RP951 RP958)**

The rapid growth of electronics, especially in communications, has saturated the environment with electromagnetic radiation (EM) emitted by TV, radios and communications equipment. These EM waves are invisible and are stronger the closer you are to their source. All electrical conductors act as antennas for EM signals and, to varying extents, all the devices may be affected by electromagnetic interference (EMI). The interference may cause unintentional movements and/or irregular control of the device.

The electromagnetic energy emitted by sources such as:

- radio stations;
- TV stations;
- amateur radio stations;
- shop alarm systems;
- cellphones and cordless phones can interfere with electric pedal exercisers.

The interference could interfere with the speed of passive pedalling. It can also permanently damage the device's electronic control unit. In our everyday environment, there are a certain number of intense sources of EMI. The intensity of the EM energy can be measured in Volts per metre (V/m). Your electric pedal exerciser is equipped with a protection against EMI which has been tested and certified as compliant with current international regulations, up to a certain intensity. This is called the "level of immunity". The greater the level of immunity, the better the device is protected. At this time, current technology can provide a level of immunity of at least 20 V/m; this is sufficient protection against the most common sources of EMI. However, we consider that the following precautions can further minimise the risk.

- A) Do not use portable radio transmitters, CB radios and avoid switching on mobile telephones or other personal communications equipment when the pedal exerciser is switched on.
- B) Do not approach powerful radio and TV transmitters too closely.
- C) If a movement of the pedal exerciser occurs that is unrelated to the program or speed set, stop using the device immediately and switch it off.
- D) Installing additional electrical accessories or components and modifying the motor of your electric pedal exerciser may make it more susceptible to EMI and hence make its use hazardous. Note that doing so also voids the warranty.
- E) In any case, report any unintentional movement of the device to your retailer or to MORETTI SPA, note it down in this manual and note down the fact that there is a source of electromagnetic waves in your vicinity, if any.

**10.1 Electromagnetic compatibility (only for RP951 and RP958)**

MANUFACTURER'S GUIDE AND DECLARATION - ELECTROMAGNETIC EMISSIONS		
THE ABOVE DEVICES ARE ONLY INTENDED TO OPERATE IN THE ELECTROMAGNETIC ENVIRONMENT SPECIFIED BELOW. THE CLIENT OR USER OF THE DEVICE MUST ENSURE THAT IT IS USED IN THESE CONDITIONS.		
EMISSION TESTS	CONFORMITY	ELECTROMAGNETIC ENVIRONMENT - GUIDE
RF EMISSIONS CISPR 11	GROUP 1	MODELS RP951 AND RP958 USE RF ENERGY ONLY FOR INTERNAL FUNCTIONING. ITS RF EMISSIONS ARE THEREFORE VERY LOW AND IN ALL LIKELIHOOD DO NOT INTERFERE WITH NEARBY ELECTRONIC EQUIPMENT
RF EMISSIONS CISPR 11	CLASS B	MODELS RP951 AND RP958 ARE SUITABLE FOR USE IN ALL BUILDINGS, INCLUDING THE HOME AND BUILDINGS CONNECTED DIRECTLY TO THE LOW VOLTAGE PUBLIC POWER GRID FOR RESIDENTIAL APPLICATIONS.
HARMONIC EMISSIONS IEC 61000-3-2	CLASS A	
VOLTAGE FLUTTER/FLICKER IEC 61000-3-3	COMPLIANT	

## 11. MAINTENANCE

MOPEDIA devices manufactured by Moretti S.p.A. are CE marked and carefully checked before being placed on sale.

Periodic inspection means examination of the following parts:

- The bearing structure of the pedal exerciser and the connection parts;
- Check assembly of the pedals and the rubber feet and functioning of the brake to adjust the exertion intensity;
- Check that all the bolts are firmly tightened;
- Check all welded points;
- Lubrication: the pedal exerciser is designed to require minimal maintenance; however, a six-monthly check and lubrication should ensure optimal duration.

**N.B.:** Use only original spare parts and accessories for repairs.



### WARNING!

If the product is damaged or not operating, immediately replace the damaged parts, otherwise leave the device out of service until it has been repaired

## 12. CLEANING AND DISINFECTION

### 12.1 Cleaning

- Use a damp cloth only. Then dry thoroughly before use.  
Do not use direct water jets.
- Do not use water at a temperature higher than 30 °C.
- Do not use water jet and/or steam washers.

### 12.2 Disinfection

- Use a common disinfectant cleaner if it is necessary to disinfect the product.
- Total disinfection of the system should be performed at regular intervals or when the user changes. Loss of colour of certain materials can be caused by certain types of sweat, UV rays, wear and tear, heat or humidity and is considered to be a natural process not covered by the warranty.

**N.B.** Never use acid, alkali or solvents (acetone or diluent) to clean it.

## 13. DISPOSAL CONDITIONS

INSTRUCTIONS FOR CORRECT DISPOSAL IN ACCORDANCE WITH EUROPEAN DIRECTIVE 2012/19/EC: 

At the end of its working life, the product must not be disposed of together with normal urban waste. It must be delivered to municipal separated waste collection facilities, or to dealers that provide this service. Separated waste disposal helps to reduce possible negative effects on the environment and health deriving from improper disposal and allows for recycling of the materials comprising the product, which translates into significant energy and resource savings. The product bears the barred bin symbol to underline the obligation of disposing of electro-medical equipment separately.

TREATMENT OF DEPLETED BATTERIES (ONLY for RP950, RP953 and RP955)   
(Directive 2006/66/EC):

This symbol on the product indicates that the batteries must not be considered as normal domestic waste. Ensuring that the batteries are discarded correctly contributes to preventing potentially negative consequences for health and the environment that would otherwise be caused by their inappropriate disposal. Recycling materials helps to conserve natural resources. Take depleted batteries to the collection points indicated for recycling. You can contact your local council, the local waste disposal service or the shop where you purchased the device for more detailed information on disposal of depleted batteries or the product.

## 14. WARRANTY

All Moretti products are guaranteed for 2 (two) years from the date of sale against material and manufacturing defects, subject to the following limitations. The warranty is voided by improper use, abuse, modifications to the product and failure to follow the instructions. The intended use of the product is indicated in the user manual. Moretti is not liable for damage, injury or any other consequences resulting from installation or use which does not comply strictly with the instructions given in the installation, assembly and user manual. Moretti does not guarantee its products against damage or defects in the following circumstances: natural disasters, unauthorised repair or maintenance, improper electric power supply (as applicable), use of parts or components not supplied by Moretti, failure to follow the guidelines and instructions for use, tampering, shipping damage (other than the original shipping by Moretti), or failure to perform maintenance as indicated in the manual. Components subject to wear and tear are not covered by this warranty if the damage is caused by normal use of the product.

Illustrative images

## 15. REPAIRS

### 15.1 Repairs under warranty

If a Moretti product has material or manufacturing defects during the warranty period, Moretti will agree with the client whether the defect is covered by the warranty. Moretti, at its sole discretion, may replace or repair the article at a specified Moretti reseller or its own premises. The costs of labour incurred in repairing the product will be borne by Moretti if it determines that the repair is covered by the warranty. Repair and replacement do not renew the warranty period.

### 15.2 Repairing a product not covered by the warranty

A product not covered by warranty may be returned for repair only if authorised in advance by Moretti customer service. The costs of labour and shipping incurred by repairs not covered by the warranty are borne by the client or reseller in their entirety. Repairs on products not covered by the warranty are themselves guaranteed for 6 (six) months from the day of reception of the repaired product.

### 15.3 Non-defective products

The client will be notified if Moretti concludes that the product is not defective after having received and examined it. The product will be returned to the client at their own expense.

## 16. SPARE PARTS

Moretti original spare parts are guaranteed for 6 (six) months from the day of delivery.

## 17. NON-LIABILITY CLAUSES

Unless otherwise expressly specified in this warranty and within the limits of the law, Moretti provides no other declaration, guarantee or condition, express or implicit, including any future declarations, guarantees or conditions of sale, suitability for a given purpose, non violation and non interference. Moretti does not guarantee that the use of its product will be uninterrupted and problem-free. The duration of any implicit warranty provided by law is limited to the warranty period, within the limits of the law.

Certain states and countries do not permit limitations on the duration of an implicit guarantee or the exclusion of limitation of accidental or indirect damages in relation to consumer products. In said states and countries, certain exclusions and limitations of this warranty may not apply to the user. This warranty is subject to modification without notice.